

Hybridizing Historic and Contemporary Methods to Realize More Sustainable Homes

Dylan Cotton

A thesis

submitted in partial fulfillment of the
requirements for the degree of

Master of Architecture

University of Washington

2019

Committee:

Rob Peña

Nina Franey

Program Authorized to Offer Degree:

Architecture

©Copyright 2019

Dylan Cotton

University of Washington

Abstract

Hybridizing Historic and Contemporary Methods to Realize More Sustainable Homes

Dylan Cotton

Chair of the Supervisory Committee:

Associate Professor/Graduate Program Coordinator Rob Peña

Hybridized building methods that integrate historic and contemporary methods and materials while simultaneously favoring locally sourced materials offer an alternative to the current trajectory of the suburban housing industry by prioritizing durability, craft, safety, and the environment above expedient profitability. Hybridization of building methods and materials from the past and present is symbiotic. The weaknesses of one building method can be offset by another. The claims of this thesis will be explored in part by hypothetically applying the proposed building methods in a large housing development that is currently under construction in Granite Falls, Washington, a place wealthy in locally sourced building materials.

TABLE OF CONTENTS

CHAPTER 1: THESIS PROPOSAL	2
1.1 <u>Introduction</u>	2
CHAPTER 2: HISTORIC AND CONTEMPORARY BUILDING METHODS	4
2.1 <u>Introduction</u>	4
2.2 <u>Historic Building Methods: Straw Bale, Cordwood, and Heavy Timber</u>	5
2.2.1 Straw Bale	5
2.2.2 Cord Wood	9
2.2.3 Heavy Timber	10
2.2.4 Historic Building Methods Precedent	10
2.3 <u>Contemporary Building Methods: Pre-fabrication, Green Building, Pile and Grade Beam Foundations</u>	12
2.3.1 Pre-fabrication	12
2.3.2 Green Building	13
2.3.3 Pile and Grade Beam Foundations	14
2.3.4 Contemporary Building Methods Precedent	15
2.4 A <u>Hybridized Building Methods Precedent</u>	17
2.5 <u>Conclusions</u>	17
2.6 <u>Chapter 2 Citations</u>	19
CHAPTER 3: CONTEXT, BUILDING STRATEGIES, AND PROGRAM	22
3.1 <u>Introduction</u>	22
3.2 <u>Context: Site and Locally Sourced Building Materials</u>	23
3.2.1 Site	23
3.2.2 Locally Sourced Building Materials	28
3.3 <u>Building Strategies: Community Design, Joining Homes, Structural Composition, And Challenging Aesthetic Conventions</u>	30
3.3.1 Community Design	30

3.3.2 Joining Homes	32
3.3.3 Structural Composition	33
3.3.4 Challenging Aesthetic Conventions	33
3.4 <u>Program</u>	34
3.5 <u>Chapter 3 Citations</u>	37
CHAPTER 4: DESIGN RESPONSE	40
4.1 <u>Introduction</u>	40
4.2 <u>Site Response</u>	40
4.3 <u>Structural Response</u>	43
4.3.1 Foundations: Stone Masonry	43
4.3.2 Building Frame: Heavy Timber	45
4.3.3 Floor System: CLT	47
4.3.4 Lateral Support: Metal Shear Panel	59
4.4 <u>Envelope Response</u>	51
4.4.1 Insulation: Straw Bale	51
4.4.2 Cladding: Cord Wood	53
4.5 <u>Systems Response</u>	55
4.5.1 Water Catchment and Storage	55
4.5.2 Heating	55
4.5.3 Solar Energy Capture	57
4.6 <u>Conclusions</u>	57
4.7 <u>Chapter 4 Citations</u>	60



(Fig. 2)

CHAPTER 1: THESIS PROPOSAL

1.1 Introduction

Current building methods for the majority of market rate suburban homes are problematic. They are based on building expediently and economically rather than being built with the environment or peoples best interests in mind. These inadequacies are partially rooted in the poor choice of building materials and processes. More appropriate building knowledge has evolved and continues to grow or lays dormant in the past and yet most single family homes do not demonstrate the implementation of this knowledge. Large housing developments sprout up with little or no community input and present a take it or leave it stance towards prospective buyers. Underutilized contemporary and historic building methods offer alternatives to the mainstream building methods and materials commonly used on suburban homes. These alternatives can better serve individuals, communities, and the environment.

Hybridized building methods that integrate historic and contemporary methods and materials while simultaneously favoring locally sourced materials offer an alternative to the current trajectory of the suburban housing industry by prioritizing durability, craft, safety, and the environment above expedient profitability. (see fig.1) Historic building methods can be improved upon by being infused with innovations that have recently emerged. Contemporary building materials such as stamped sheet metal shear panels and tension cables could be hybridized with historic wall assemblies such as cord wood or straw bale. Driven concrete piles capped with grade beams could accommodate the width of historic wall assemblies. Experimentations with the hybridization process such as these may help realize justifiable alternatives to common suburban building assemblages.

Hybridization of building methods from the past and present is symbiotic. The weaknesses of one building method can be offset by another. The labor intensiveness of historic building methods can be neutralized by better productivity linked to contemporary building methods. The costliness of contemporary methods can be balanced by the frugality of historic methods. The specialized

skill and manufacture associated with contemporary building methods can be counter balanced by the inclusiveness of skill needed to execute historic methods.

The contention of this thesis is that the suburban housing industry has disregarded the best building methods from both the past and the present. Despite having the knowledge and skills to build durable, environmentally and socially conscientious housing most housing developments continue to be built in a short sighted irresponsible manner. Exploring sustainable alternatives to the conventional methods that proliferate the suburban housing industry will offer positive alternatives to displace unsustainable building methods.

The claims of this thesis will be explored in part by hypothetically applying a series of proposed building methods to a large housing development that is currently under construction in Granite Falls, Washington. Having a large scale development composed of homes built in an alternative way would help to create a dialogue between homeowners in the Granite Falls area who could then discuss their opinions surrounding how to build homes in their area. Placards placed in open areas for prospective buyers to see all of the alternative building methods that could be used to build their houses and to offer greater programmatic variability through design could be integrated into the open spaces.

CHAPTER 2: HISTORIC AND CONTEMPORARY BUILDING METHODS

2.1 Introduction

Environmental and societal issues can be addressed through the appropriate choice of building methods. Health issues that may stem from the exposure to toxins within common building materials can be avoided by prioritizing building methods that use less processed or toxic building materials and processes. Prioritizing building methods from the past and present based on their ability to utilize locally sourced materials and how easily they can be transported because of their size reduces the energy spent transporting and processing the building materials to be used. Using inclusive building methods can draw upon community involvement and less specialized labor.

The labor intensive nature of many historic building methods has made them less popular in the construction industry. The inclusivity of the labor needed to build with these methods can partially offset their greater dependence on labor when compared to common building methods. Some historical building methods can be interpreted as more inclusive because of the reasonable size of the building components used and primitive tools needed. A common suburban home has hundreds of components weighing an unreasonable amount. Some alternative historic and contemporary building methods utilize more reasonably sized building components that could be implemented in place of the less inclusive, excessively heavy building components associated with common building methods.

Particular contemporary building methods have the ability to reduce the amount of labor needed to produce homes of the same quality (or better quality) compared to homes that are common to current suburban housing developments. Using contemporary building methods also provides opportunities to build homes in a more environmentally sound way. Historic building methods will be examined first in this chapter followed by an evaluation of contemporary building methods.

2.2 Historic Building Methods: Straw Bale, Cord Wood, and Heavy Timber

Some historic building methods offer the benefits of using less energy, being less toxic, and being more inclusive in their process. The diminished energy used to process and transport locally sourced materials means that they have less “embodied energy” (Chiras, 11). Historic building methods in particular present the opportunity to utilize locally sourced materials that do not have to be highly processed. The highly processed materials used currently on common homes use more energy due to their manufacture and transport compared to historic building methods that utilized locally sourced materials. “Intergenerational equity” or the concern for future generations can be practiced by choosing building materials with less embodied energy (Chiras, 13).

Some of the materials associated with historic building methods have fewer embedded toxins because they are less processed. They are also more likely to be less dependent on the type of periodic maintenance that requires products that have toxins, such as paint. Historic building methods are often less audibly disruptive during construction than common building methods, which often have overlapping layers of acoustic disruption from pneumatic and electric power tools alike.

Most historic building methods did not utilize the large numbers of fasteners currently used in contemporary home building. This myriad of fasteners makes the probability of material recycling and reuse more problematic and difficult compared to the possibility of re-use of materials in historic buildings. Contemporary builders would be wise to incorporate historic building methods which use fewer fasteners into their work in order to promote the future dismantling and re-use of building materials. Straw bale, cord wood, and heavy timber will be discussed to help affirm the validity of their implementation.

2.2.1 Straw Bale

Straw bales can be made from the remnant fibers that are discarded when grains are extracted during their respective harvesting processes. The resulting “bale” made from these discarded wheat fibers is roughly forty inches long, eighteen inches wide, and four-

teen inches tall. There is great variation in the size that bales can be made, all the way up to large rounds that are several tons. Wheat straw is the most common to Washington State. Straw bale walls present great opportunities for economic and environmentally sound buildings, but they do present challenges, some of which are “moisture, insects, rodents, and fire” (Chiras, 64). There is an abundance of straw available annually from Eastern Washington that could potentially be made into straw bales for use in home building. Straw bale walls thermally outperform common wall assemblies (Birkland, 197). Because of this thermal performance straw bale walls could help reduce the release of “22,000 pound[s] of carbon dioxide each year” that is accredited to single family homes (Quale, 16). A 1994 life-cycle cost analysis comparison between modest homes of the same size built with common wall assemblies and straw bale wall assemblies in a moderate climate proved that the straw bale example performed better over both 30 and 100 years (Birkland, 198).

Straw bale walls were first used within the United States in Nebraska in the 1880’s (Birkeland, 197). One such example is the Simonton House in Purdum, Nebraska which was built in 1908 (Chiras, 65). (see fig.2) They have had a resurgence in the United States recently, mostly in areas closest to straw bale sources. Robert Young of Red Feather Development Group has used straw bale walls to provide affordable, efficient, and empowering homes for at risk Native Americans whose lands produce wheat (Rizzo, 1). Homes built with straw bale walls have been built recently in areas of western Washington that have similar site conditions to the proposed building site in Granite Falls, Washington (Shrestha, 1). Living Shelter Design has designed over twenty straw bale projects that have been completed throughout Washington State, some of which are in the Puget Sound region (Saldivar, 1). There are recent building codes that facilitate straw bale construction (ICC). (see fig.3) The fact that a building code agency is willing to recognize and codify rules for construction of straw bale homes support the idea that straw bales are indeed a feasible building material to use. Because straw bale walls call for a stucco layer on both interior and exterior surfaces the finishing process requires little skill and only very basic tools. Because of this, this building method is highly accessible in terms of community involvement. It is also economical due to the unskilled nature of the labor required. Instead of paying for labor home owners and their families might reasonably be able



(Fig. 2)

AS101.2 Strawbale wall systems.

Strawbale wall systems include those shown in Figure AS101.2 and approved variations.

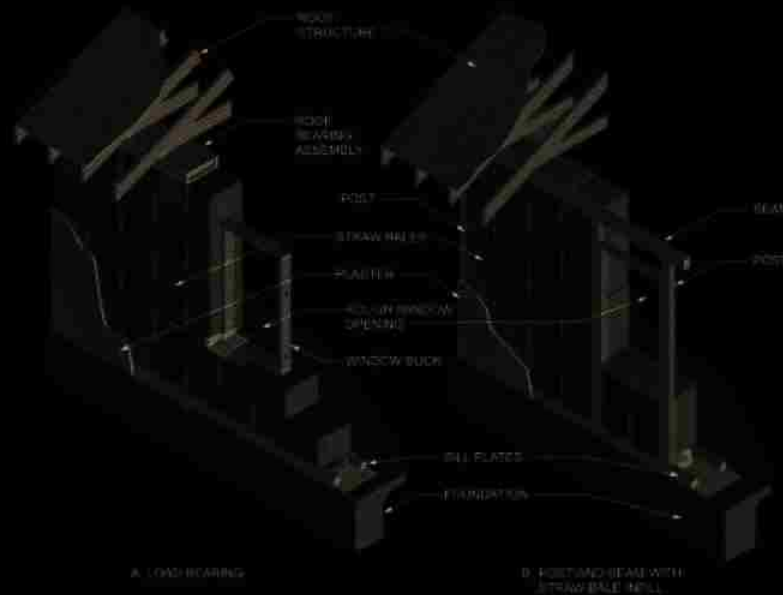

NOTE: SEE FIGURES AS106.1(1) THROUGH AS106.1(4) FOR DETAILED VIEWS AND SECTION REFERENCES. OTHER STRAWBALE WALL SYSTEMS OR VARIATIONS ARE PERMITTED AS APPROVED.

(Fig. 3)

to do whatever maintenance is required on their own or participate in the initial construction. The upkeep needed also has the benefit of not being toxic, making it more reasonable to use. This is because interior stucco layers do not require the “taping” or “texturing” that are required in typical drywall/sheetrock applications. Each of these processes involve volatile organic compounds that contain known toxins.

Instead of achieving shear strength with thicker and stronger exterior stucco layers, alternative high performing contemporary building methods could be used in conjunction with the stucco layers to achieve the needed shear strength. More locally sourced clays and sands could then be used in place of more energy dependent exterior stucco layers that have higher levels of concrete. This would help allow easier maintenance to the wall assembly and open the possibility to adaptive exterior claddings that could change with the seasons.

2.2.2 Cord Wood

Similar to the straw bale wall assembly cordwood walls can utilize a byproduct. Harvested timber with smaller diameters or crooked lengths are both less desirable to millers. This timber could be diverted from the mills and used for cordwood walls. This smaller diameter timber would otherwise be processed into landscaping products such as bark or manufactured wood products such as oriented strand board. The active logging operations in Snohomish County could serve as a source of materials for cordwood walls. The clients of these logging operations would likely relinquish less desirable logs, especially if a higher price than what they were getting is offered.

Early use of cordwood walls in the United States happened in Wisconsin in the 1850’s (Chiras, 168). Homebuilders were able to utilize the abundant local forests and not rely on milled lumber. There are three primary permutations of the cordwood wall, each version being appropriate depending on the situation (Chiras, 170). All types have an inner and an outer layer with a cavity in between

for insulation. (Chiras, 170). The most common type of insulation used between the inner and outer layers of this wall system is moist sawdust mixed with lime, the sawdust could be acquired from the same supplier of the cordwood or a local mill (Chiras, 176). Cordwood walls certainly have the possibility of being durable as "...many cordwood buildings in Canada, Sweden, and Wisconsin are over one hundred years old" (Chiras, 179).

2.2.3 Heavy Timber

Heavy Timber can be considered both a historic and a contemporary building method. Heavy timber precedents from the past show that highly processed structural members are not a necessity. Roughly processed members were utilized despite their lack of complete linearity or other imperfections. Historic examples of heavy timber structures show that craft can execute higher levels of structural resolution with integrated connections between structural members even though they were executed with rudimentary tools. This is particularly compelling when these historic examples are compared to similar structures of today that have had all the advances in tools, building systems, and fabrication at their disposal. The logging industry is active in Snohomish County, fueling mills near the site that could serve as a source of heavy timber. The trees that were cleared from the site to make way for the new housing development could also be hypothetically used by hiring a mobile milling service to mill the timber onsite.

2.2.4 Historic Building Methods Precedent

One example of a structure using a historical method described above is the Earthwood Building School that was built in 1995, located in Northern New York State near the Canadian border, built with cord wood walls by Rob Roy, "...North Americas preeminent expert on the subject..." of cord wood construction (Roy,1 Chiras, 169). (see fig.4) The building has, "...a round shape, earth sheltering, cordwood masonry, solar orientation, and a 23 ton wood-fired masonry stove..." (Roy,1). Because the stone masonry woodstove is centrally located the thermal mass of the fireplace releases heat back into the house (Roy,1). "It grieves me to see so many masonry

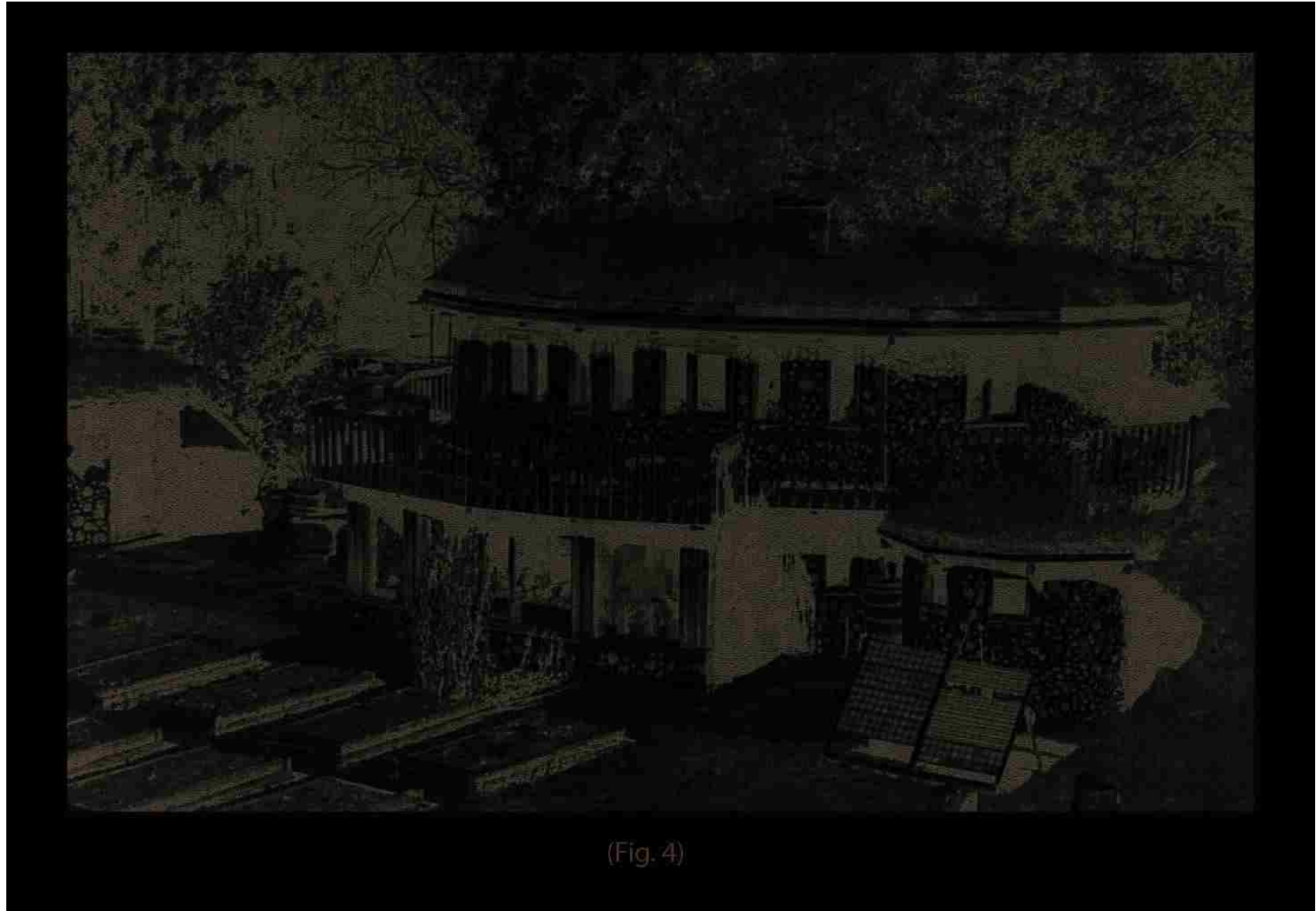

(Fig. 4)

chimneys fastened to the outside of the gable end of a house.” (Roy,1).

While this precedent was highly economical to build and to sustain throughout a typical year it is naïve to think this precedent could be replicated anywhere. The white cedar used on the home outperforms most other wood species that could also be used to construct cordwood walls. The home is not as vulnerable to seismic damage compared to homes that are west of the Cascade Mountains. This has made reinforcing the cordwood walls much easier as no steel mesh or rebar is needed to make the walls capable of withstanding a seismic event.

2.3 Contemporary Building Methods: Pre-fabrication, Green Building, Pile and Grade Beam Foundations

Contemporary building methods can help to relieve the inefficiencies of the historic building methods they are hybridized with. They can also outperform common building methods in every way except in regards to initial cost. They can also displace the environmentally detrimental characteristics of common building methods. The higher level of craft present in some contemporary building methods can increase build quality and the likelihood of eventual reuse of building materials.

2.3.1 Pre-Fabrication

In 2008 the National Research Council made five recommendations to help reduce construction expenditures in the United States (Smith 77-78). “Greater use of prefabrication, preassembly, modularization, and offsite fabrication techniques and processes...” was one of the five (Smith, 78). Smith goes on to present research showing that construction productivity has gone down between 1964 and 2004, showing there is a place for prefabrication to help alleviate labor costs on building projects through greater production efficiencies (Smith, 79).

Contemporary pre-fabrication has an ambiguity of scale, building components or full assemblies can each be characterized as being pre-fabricated. Pre-fabricated building components of a smaller scale offer the possibility of supplanting the deficiencies of

historic building methods such as inadequate structural performance and inefficient assembly and disassembly. Pre-fabricated components can also be used in part or wholly to replace the common building practices that would otherwise be used. “The capacity of prefab to deliver buildings that respond to time, change, reuse/recycle may be its greatest benefit toward total lifecycle sustainability in the future” (Smith, 220).

The predictability, precision, and quality realized through pre-fabrication have the counter argument of being less cost-effective (Smith, 81). This is why discernment in the overall proportion of pre-fabricated building elements that are used to construct a home must be carefully determined; especially because of the financial constraints dictating the feasibility of a new home’s construction. Even if a home has reduced life-cycle costs, higher initial cost can make a home unattainable to homebuyers. “Designing for assembly and disassembly is a strategy for the ultimate cradle to cradle cycle.” (Smith, 222). Pre-fabricated building components that are used as part of a sub-assembly or full assembly can contribute to this strategy by using fewer fasteners that each can be installed as easily as they can be taken apart.

2.3.2 Green Building

People and the environment pay the true cost of using cost effective building products that have unreasonable levels of toxins or are transported from great distances. Because of their initial cost effectiveness additional shipping costs are more likely to be accepted despite the added energy expended. Alternatives to these building products are available that have minimized toxicity and contain post-consumer waste.

“Green homes are safe to live in, affordable to operate, and less damaging to the local, regional, and global environments”. (Wilson, vi) “A green product is one whose life-cycle impacts are low.”(Wilson, vii). Building products and methodologies that are categorized as “green” divert waste streams, minimize toxicity, and respond to environmental conditions (Wilson, vii-xii). Using

“green” caulks, adhesives, and paints on the project would be some of the prioritized “green” building products to be utilized. Volatile organic compounds (VOCs) are particularly toxic, especially to those who are applying conventional caulks, adhesives, or paints (Wilson, 195). VOCs allow building products to be applied wet before they then dry (Wilson, 195). While “green” products can address nearly every building need when considering all the possible national or global companies that supply such materials finding locally sourced “green” products are preferred because of the reduced energy that would otherwise be expended while shipping.

Using only the “greenest” building products is not always possible because their availability is not as predictable as common less conscientious building products.

2.3.3 Pile and Grade Beam Foundations

The foundations of common suburban homes built presently will outlive the homes that are built upon them, they are excessively durable. Most of them will be demolished as the houses on top of them become dilapidated despite having plenty of use left. While contemporary foundations are very economical due to the durability of concrete and the moderate level of skill needed to complete them, they are not built with re-use of materials in mind. There are more environmentally conscientious contemporary options that save resources in the long-term due to the less energy needed to eventually re-purpose the materials used.

Driven pre-casted concrete piles require high levels of craftsmanship and expensive specialized equipment to fabricate and install. They could be removed and possibly reused when the buildings they support are to be demolished. The grade beams that rest on top of the piles could be built to accommodate wider wall assemblies such as cordwood or straw bale. The grade beams could be constructed in part out of locally sourced stone. A pile with grade beam foundation is more environmentally conscientious because it offers the possibility of using less overall concrete than a common foundation. Because the building site is relatively flat using piles with grade beams as a building method for foundations is appropriate.

2.3.4 Contemporary Building Methods Precedent

A precedent built using contemporary methods is the “...ecoMod 1, called the OUTin house, [which was] designed, prefabricated off-site and sited in the Fifeville neighborhood of Charlottesville...”, Virginia and completed in 2005 (Quale, 93,106). (see fig.5,6) The three story two unit housing building was built collaboratively by the University of Virginia and Piedmont Housing Alliance (PHA), an affordable housing organization (Quale, 90, 93). Community concerns were addressed throughout the design process by consulting the “Fifeville Neighborhood Association” (Quale, 97). This project had the same budget that other projects that have been completed by the PHA had (Quale, 97). Completing the project within a typical budget was possible by getting free workshop space to pre-fabricate building components and free design and construction labor. This brings into question whether pre-fabrication is close to being economically viable for small scale housing projects with limited budgets. Some of the many feature of this building are structurally insulated panels, potable rainwater collection, solar hot water heater, and low/no VOC interior materials (Quale, 112-113).

While this precedent performs well, was designed conscientiously, and fulfilled a need for people struggling to provide housing for themselves this precedent is a problematic precedent to try and replicate in some regards. Housing developers operate in many areas and states, having a dedicated facility for preassembling building components would require a large amount of space. This added cost to the developer would then be redistributed to all the sale prices of the homes they produce. Much of the design analysis studies were done by students free of charge and were choreographed by an expert. This design expertise and labor would come at a greater cost if done to the same level of thoroughness by a large housing developer. The site response for the Outin house is difficult to replicate in a housing development with hundreds of houses. Designing to respond to solar orientation is an afterthought in most medium to large scale housing developments. Most large housing developments have windows oriented indiscriminately as homes have been arranged to maximize homes per development.

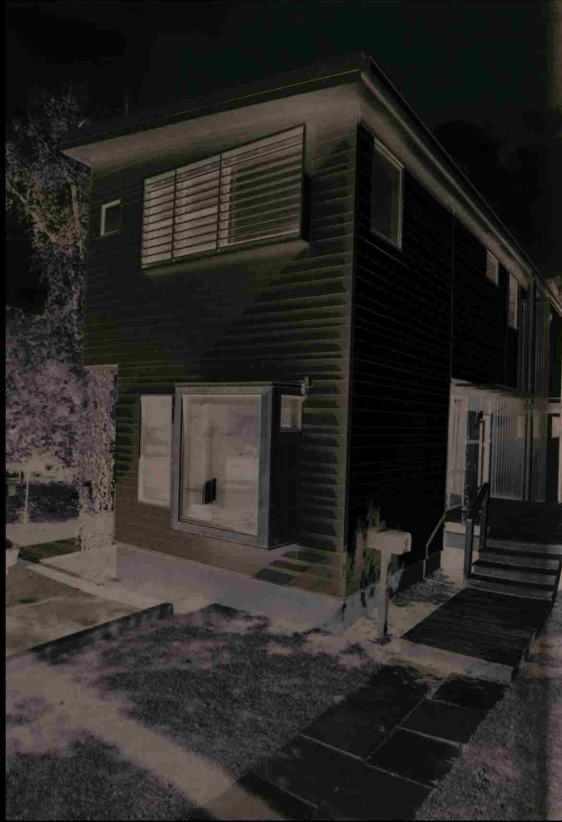

(Fig. 5)



(Fig. 6)

2.4 A Hybridized Building Methods Precedent

The Primary School built in Gando, Burkina Faso between the years 1999 and 2001 is a good example of a building that has combined building methods from the past and the present (Lepik, 33-34). (see fig. 7,8) The traditional locally sourced mud bricks have been augmented through additional compression and added concrete to the mud mixture, roughly 6% (Lepik, 34). The space frame roof has been economically executed with rebar (Lepik, 34). The architecture has fulfilled a need without strictly adhering to either historic or contemporary building methods. Concrete bricks were typically used to construct schools in Burkina Faso (Lepik, 34). By using locally sourced materials and labor some of those who worked on the project were able to continue working in the same region using the skills they had learned on this project (Lepik, 34). This project shows that revitalizing historic building methods that respond to a sites resources can benefit more than those that use the completed project.

2.5 Conclusions

While contemporary building methods have their benefits they still have drawbacks associated with higher initial expense that makes their implementation prohibitive to most developers. The majority of suburban home developers have resisted implementing the best contemporary building methods despite the long term cost savings and health benefits that could be passed on to homeowners.

Historic building methods that utilize locally sourced materials perform better than conventional building methods in regards to life-cycle costs and the overall embodied energy within the building materials themselves. These characteristics better serve both consumers and the environment. The labor intensive nature associated with historic building methods is not consistent with the expedient expectations of housing developers which is one of the main reasons they have not been utilized more often by developers. This glaring deficiency can be addressed by hybridizing contemporary building methods with historic ones.



(Fig. 7)



(Fig. 8)

2.6 Chapter 2 Citations

- Birkeland, Janis. *Design for Sustainability : A Sourcebook of Integrated, Eco-logical Solutions*. London ; Sterling, VA: Earthscan Publications, 2002. Print.
- Chiras, Daniel D. *The Natural House : A Complete Guide to Healthy, Energy-efficient, Environmental Homes*. White River Junction, Vt.: Chelsea Green Pub., 2000. Print. The Real Goods Solar Living Book.
- ICC. "APPENDIXS STRAWBALE CONSTRUCTION ." *APPENDIX S STRAWBALE CONSTRUCTION | 2018 International Residential Code for One- and Two-Family Dwellings | ICC PremiumACCESS*, codes.iccsafe.org/content/IRC2018/appen-dix-s-strawbale-construction.
- Johnson, Danielle. "First Spec Strawbale Homes in WA." *Building Seattle Green*, 27 Sept. 2006, blog.seattlepi.com/greenbuilding/2006/09/27/first-spec-strawbale-homes-in-wa/.
- Lepik, Andres., and Museum of Modern Art. *Small Scale, Big Change : New Architectures of Social Engagement*. New York : Basel: Museum of Modern Art ; Birkhäuser, 2010. Print
- Quale, John D. *Sustainable, Affordable, Prefab : The EcoMOD Project*. Charlottesville: U of Virginia, 2012. Print.
- Rizzo, Will. "Homes on the range." *Best Life*, Apr. 2008, p. 066. *Academic OneFile*, http://link.galegroup.com/apps/doc/A179727127/AONE?u=wash_main&sid=AONE&xid=5144eae9. Accessed 20 Apr. 2019.
- Roy, Rob. "Rob Roy's Earthwood Home." *Mother Earth News*, no. 149, 04, 1995, pp. 60. *ProQuest*, <https://search.proquest.com/docview/210568165?accountid=14784>.
- Saldivar, Lisa. "Straw Bale Construction." *Living Shelter Architects*, Living Shelter Architects, 31 May 2018, www.livingshelter.com/blog-list/2018/5/31/straw-bale-construction.

Shrestha, Bibeka. "Straw-Bale House Won't Blow Away." *The Seattle Times*, The Seattle Times Company, 24 Sept. 2007, www.seattletimes.com/business/real-estate/straw-bale-house-wont-blow-away/.

Smith, Ryan E. *Prefab Architecture a Guide for Architects and Construction Professionals*. Hoboken, N.J.: Wiley, 2011. Web.

"Wheat." *Washington Grain Commission*, wagrains.org/all-about-wheat/varieties-of-wheat/.

Wilson, Alex, Piepkorn, Mark, and Malin, Nadav. *Green Building Products : The GreenSpec Guide to Residential Building Materials*. Brattleboro, VT : Gabriola Island, BC: BuildingGreen New Society, 2005. Print.

Fig. 1-Generated by Dylan Cotton

Fig. 2-Chiras, pg. 65

Fig. 3-<https://codes.iccsafe.org/content/IRC2018/appendix-s-strawbale-construction>

Fig. 4-Chiras, pg. 169

Fig. 5-Quale, pg. 88

Fig. 6-Quale, pg. 106

Fig. 7-Lepik, pg. 35

Fig. 8-Lepik, pg. 40

CHAPTER 3: CONTEXT, BUILDING STRATEGIES, AND PROGRAM

3.1 Introduction

Almost everyone in America is affected by the persistence of suburban sprawl particularly children and the elderly (Duany, 115-116, 122-124). Well intentioned scholarly analysis and solutions aimed at this sprawl have not changed the minds of the majority of developers and consumers who continue to disregard these alternatives. The Charter of the New Urbanism is now more than 20 years old, it clearly lays out how to remediate suburban sprawl and yet large housing developments continue to be built in a typical manner (Duany, 254, 259-261). Housing developments at the edge of suburban sprawl are the most susceptible because resistance from the community and local building departments is less likely to be present. Addressing suburban sprawl with incremental changes that implement alternative building methods and strategies may help to bring about more comprehensive eventual change to the suburban housing industry later on in the future. Alternative building methods can begin to address some of the overall issues facing suburban homes by serving as a catalyst for more comprehensive change.

The history of Granite Falls can be expressed materially through site response. Cordwood walls are reminiscent of the stacked logs ever present in the logging industry. The long and continued history of mining in the Granite Falls area can be expressed with stone. Building strategies that further the improvements realized by hybridizing historic and contemporary building methods offer the possibility of strengthening the proposed project.

The site can help determine what building materials are appropriate and how a home can best respond to the site through design. The path of the sun in relation to the site and the placement and size of all eventual buildings on the site can help resolve the placement of fenestrations and thermal mass. Prevailing winds can help determine passive cooling and ventilation.

Community involvement in the planning and execution of a large housing development can help that development avoid the

formulaic results and repercussions often realized in a lot of single-family housing developments. This community involvement can be facilitated with areas available to the community to meet as a whole to arrive at collective decisions.

3.2 Context: Site and Locally Sourced Building Materials

3.2.1 Site

Granite Falls, Washington is north and east of Seattle in Snohomish County. (see fig.9) First settled by non-natives in the 1880s Granite Falls became a town shortly after their platform along the railroad was replaced with a station and depot that was completed in July of 1894 (Kirk, 258-259, Woodhouse, 48). The same tracks that would eventually carry ore from Monte Cristo to Everett transported timber to and from the lumber and shingle mills that operated near Granite Falls (Woodhouse, 48,111). By the 1930s the train tracks between Granite Falls and Monte Cristo were replaced by roads (Woodhouse, 149). Large-scale logging continued in the area until the Endangered Species act disallowed most of the logging closest to Granite Falls (“Granite Falls, Washington”).

Granite Falls in recent times has been a partially forested area with sparse farmland, but with the area’s population rising, undeveloped lands are giving way to single-family home developments. (see fig.10) Given Granite Falls’ wealth of local building materials and proximity to geologically and ecologically sensitive areas, building conventional suburban homes here seems inappropriate. (see fig.11) Building in a more sustainable manner would help to maintain the natural beauty of the area while simultaneously creating more livable and less toxic homes for buyers.

The site selected is located in the Northeast corner of the city, just within the city limits. (see fig. 12) Plans to develop the site were in place before the recession that began in 2008, by December of 2016 work had begun on the first 95 of the eventual 327 homes that will be built on the site (Bray, 1). Before being developed for single-family housing the 82 acres of the site were used for dairy farming (Bray, 1). This development represents a significant contributor to the population growth within the city limits of Granite



SITE'S ECOLOGIC VULNERABILITY

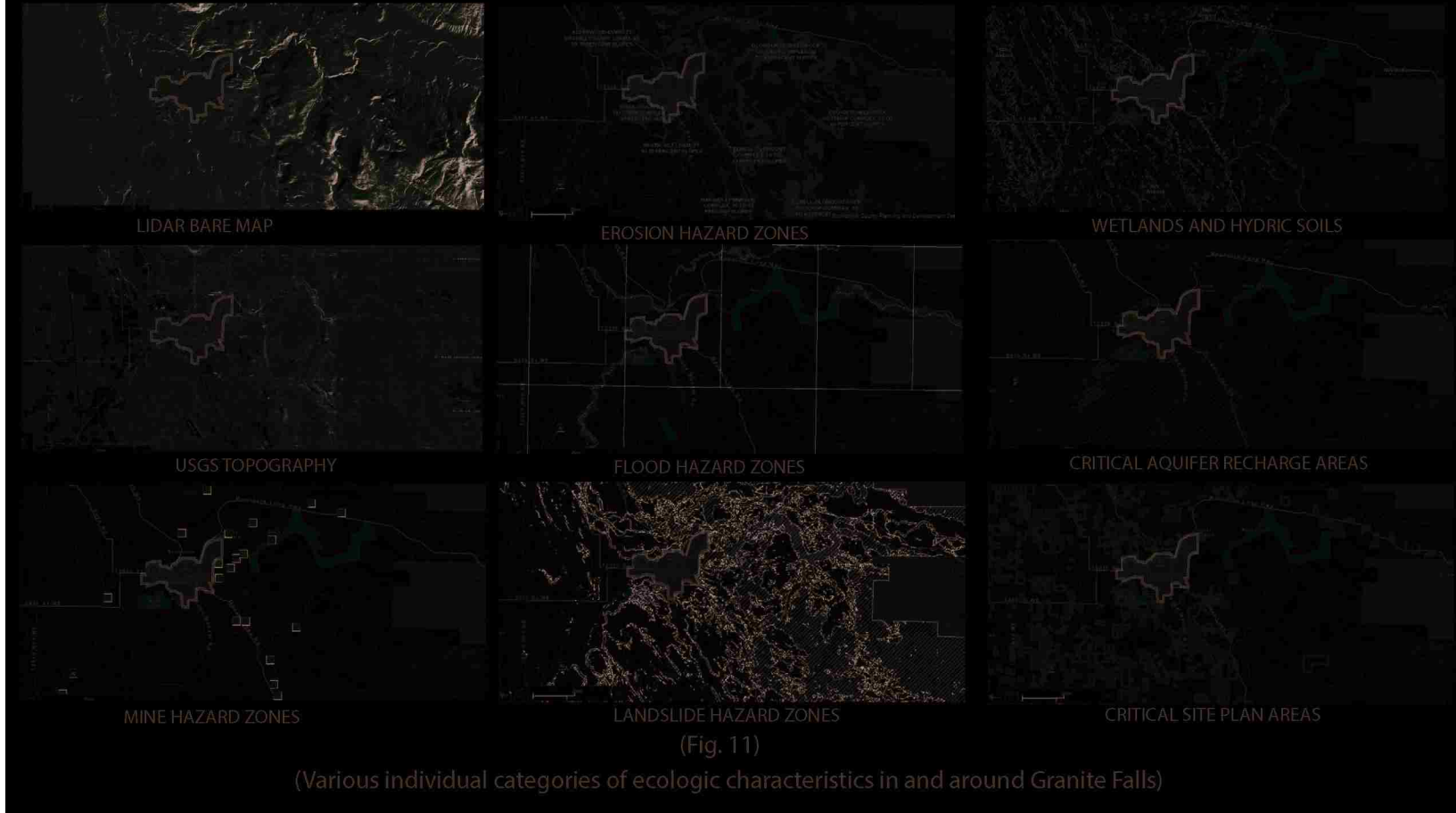



Falls, census data from the year 2011 shows the population within the city limits was 3,370 (Snohomish County, 7). This population growth is scheduled to continue as the targeted population accepted by Snohomish County planners is 7,842 by the year 2035 (Snohomish County, 7).

3.2.2 Locally Sourced Building Materials

Granite Falls is wealthy in local resources that can be used for building. Most areas do not have the luxury of utilizing locally sourced building materials to the extent that Granite Falls can. (see fig.13) Granite Falls is a prime candidate to employ a hybridized building method of construction using local resources. Cord wood, straw bale, heavy timber, metal shear panels, and stone can all be locally sourced.

Even though the likeliest source of straw bales would be Eastern Washington one of the closest suppliers of straw bales to the site is Dayville Hay & Grain. They have the capacity to store and eventually deliver the needed straw bales. Because straw bales must stay absolutely dry until they are covered in stucco having a local supplier who has the capacity to store the bales properly before they are used in construction is imperative.

The three large logging companies nearest to Granite Falls (Lorric Logging, D&D Logging, and Northern Land Management) could be contracted to provide the cordwood for cordwood wall construction. These companies are some of the larger logging companies in Snohomish County. Clients who hire these contractors to harvest timber from their land would likely be willing to part with the less desirable timber from there land, especially if a higher price than what the mills offered was presented. The logging companies could convert the timber into cordwood of the desired lengths to be used on the proposed project.

The likeliest source of heavy timber would be Buse Lumber a large scale saw mill in Everett, Washington. They would likely have less desirable timber with imperfections that could provide the same structural integrity at a diminished cost.

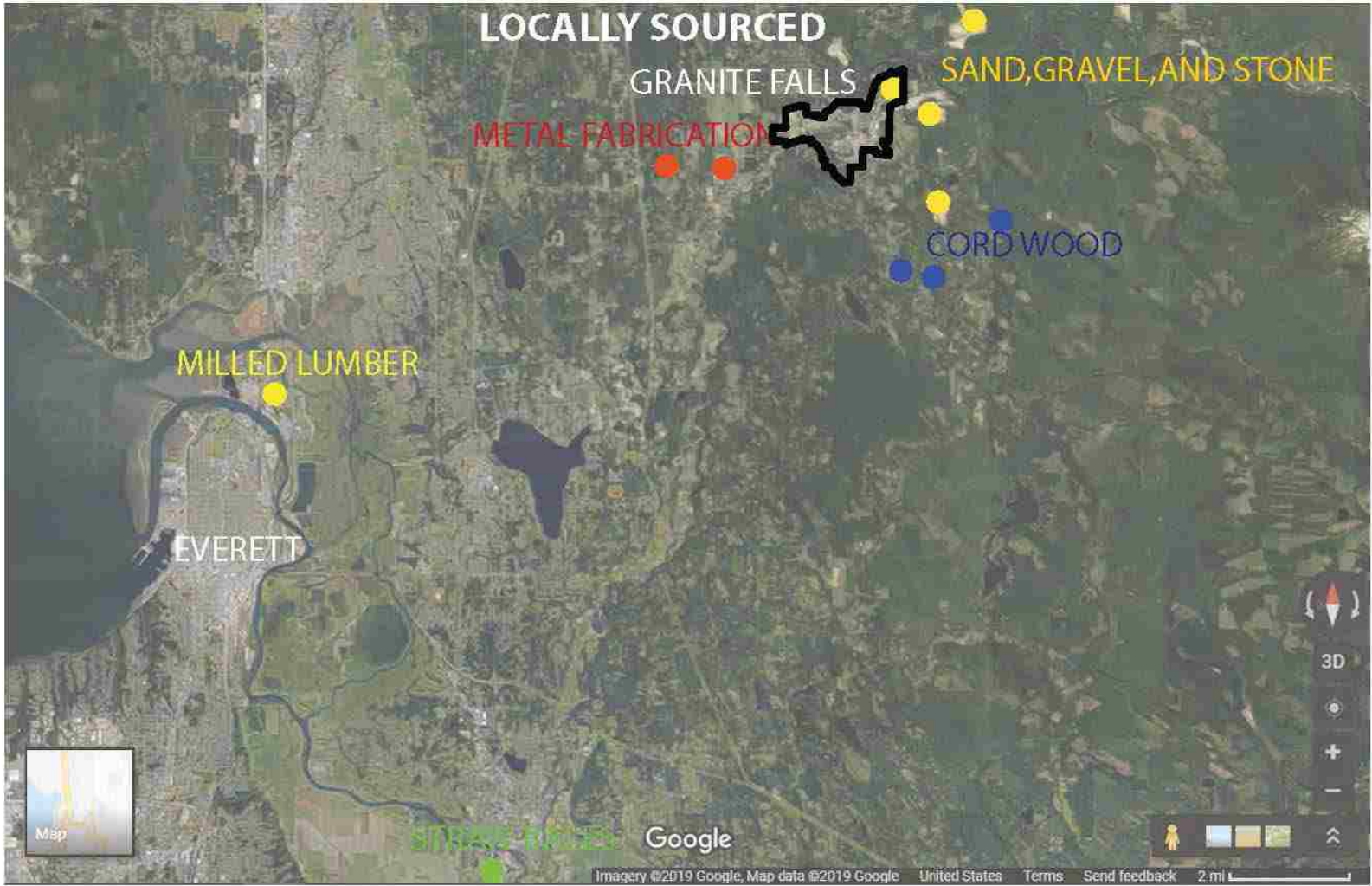

(Fig. 13)

Pre-fabricated steel building components could be made by local metal workers such as Iron Star Welding and Advanced Mobile Welding. Structural connections between foundation and structure and also connections between structural members could be resolved with products supplied by these metal workers.

The most abundant local resources available to builders in Granite Falls are sands, gravels, and stone; all of which are available in great variety and nearly inexhaustible quantity. The primary sources for these materials would be Cadman Inc., Priceless Granite, Iron Mountain, and Menzel Lake Gravel.

All of these local suppliers of building materials may be more likely to narrow their profit margins when informed of that their products were serving the local community.

3.3 Building Strategies: Community Design, Joining Homes, Structural Composition, and Challenging Aesthetic Conventions

Choosing specific building methods alone cannot help an unbuilt project fully realize that projects potential. The context of a site can shape a buildings form and determine the materials to be used but using context alone also falls short in determining what is all together appropriate for any building. Perpetuating aesthetic conventions with façades of truth is dishonest to homebuyers. Building strategies need to be employed in addition to building methods and site response to help a project fully realize the potential it is capable of.

3.3.1 Community Design

Housing developments are usually composed of homes and nothing but homes this is detrimental to the community. Community events that bring the community together are harder to plan and carry out when space within a neighborhood have not been dedicated for the community to meet. Without community input in the planning of a housing development the primary decisions that will determine the functionality of the community are left to the developer. Even if a community is impartial about the way a housing

developer plans to arrange houses and fences the developer has a responsibility to provide alternatives to the community and prospective buyers. If alternative building methods and programmatic arrangements were offered then consumers may collectively choose them even in smaller groups. Maybe a group of four families would decide to pool their yard spaces together because they think their children will play together.

Assuming that involving a community in the planning process will bring about the best results is problematic, the larger a community is the harder it is to come to consensus decisions. This is why subdividing a development with each division being allowed to adapt to their own needs may be a possible way to address the logistical difficulties associated with having a whole community coming to a singular decisions. “What happens before, during and after the community consultation process requires reassessment. Practitioners must question whether existing processes truly elicit community meaning and values.” (Birkland, 107). Community meetings that address a communities concerns with only existing community members when considering the outcomes of an inevitable housing development only brings their concerns to light without any input from the prospective buyers. Bringing prospective buyers together with existing community members to discuss each stake holder’s opinions towards a prospective housing development may help bridge the possible divide between new and existing community members through the negotiation process. Any conflicts of interest that may lead to further divisiveness within that community can be addressed proactively instead of in a reactionary manner.

Mark Francis argues that “...there is an ongoing need for more systematic ways to know what works and does not work in community design...”, that there is no prescriptive approach to community design, but many existing strategies (Francis 18-19). Of the four categories of case study strategies in regards to “community design” that are designated by Francis “Issue-Based” seems most applicable to the design strategy of this thesis (Francis 21). Applying this analytic framework would mean to question how community participation may affect the look and quality of the resulting project. How is the balance between community satisfaction through

participation and quality control of the resulting project result well? The issues being addressed through design can be done so with community input and involvement to strengthen the potency of the proposed project.

The green space of the proposed project will act as a place to facilitate community design principals with placards that communicate all the alternative building methods that are used in the development. Because Granite Falls High School is across the street from the site the community building could also serve as a place to provide vocational training to interested students. These students could also be called upon to participate in the construction of homes that are implementing the proposed building methods and strategies.

3.3.2 Joining Homes

Liberties with building code adherence would be allowed within the proposed development to open the possibility for home owners to join their homes with other owners if they so desire. Single homes of the existing development will be replaced in part with homes that have been fused together in groupings of two and four. Row houses have the opportunity to have shared stairways between every two linked houses. Party walls between connected homes do not have to be built to resist the weather, saving materials. The extra space generated from eliminating the space between individual homes can be redistributed to give greater depth to back or front yards. Maximizing one yard size by having fewer overall yard spaces around a house at the expense having individual homes allows for more capitol to be dedicated to the quality of the building. Once single-family homes have been built their owners can be resistant to any future efforts to densify the areas that they occupy. Larger yards are more likely to have eventual housing units build on them farther in the future when a new generation is occupying the houses whose former occupants would be gone. The community space of the development could serve as a place for prospective home owners to meet each other and determine whether they would like to join their houses together with one another.

3.3.3 Structural Composition

Common structural composition on typical homes has minimally sized components spaced regularly, this type of structure is referred to as “stick framed”. The structural composition of common homes has predestined them to end up in a landfill in the future. A common home has tens of thousands of fasteners with each individual fastener much harder to remove than it was to install in the first place. Because adhesives are often used in conjunction with fasteners this makes the eventual reuse of any of the building materials on a common home a near impossibility. Greater spacing between structural members compared to common structural arrangements reduces the overall amount of fasteners needed to complete a home. The connections between structural members and the layered assemblies attached to the structure under these circumstances have to have greater resistance to force; facilitating high performance fasteners that are easier to build with. These types of fasteners make eventual disassembly more plausible. Structural members increase in size as the spacing between structural members increases. A large wooden structural member with fewer fasteners connected to it is easier to repurpose (when initial purpose is over) than a smaller wooden structural member with many fasteners attached to it. If imperfections in the structural members were allowed while still fulfilling structural needs then less desirable wood members could be used that would otherwise be used for manufactured wood products or re-milled into smaller members.

3.3.4 Challenging Aesthetic Conventions

Challenging the aesthetic expectations consumers have for their new homes is important because many sustainable alternatives to common building methods look different. For instance new homes might “Facilitate public education by making environmental systems visible, so people know where resources come from and where wastes go (whether linear or circular)” (Birkland, 67). Exposing building systems in a home saves cost, as the extra effort needed to conceal systems is diminished. In addition, taking this design approach may help lead to more systems integration within the overall project. For example; if a gabion wall filled with crushed stone

is used for a garage wall; the ventilation needed for the garage can be achieved by the inherent characteristics of the wall itself and no ventilation system for this area would be needed. This circumstance makes conditioning the space difficult but the approach would provide adequate protection from theft and precipitation.

Exterior and interior surfaces that have to be painted or stained on site will be avoided as they are a detriment to workers and occupants. Occupants must rearrange their interior spaces to gain access to walls and ceilings that require periodic reapplication of paint. As landscape elements around a house mature they impede the eventual reapplication of exterior paint or stain. Workers who have to apply paint and stains on site to surfaces as a profession are exposed to fumes; they also risk exposing others nearby to these fumes as well. Textiles and art can be used to add character to walls and ceilings in place of paint. Pre-finished materials that do not need any on-site finishes can also be used in place of on-site paint dependent surfaces. Color can also be expressed architecturally through the creative use of materials which are naturally colorful.

Fences typically divide properties and use great quantities of valuable materials. Home owners often plant landscape elements against their fences. Neighboring home owners may be willing to allow agreed upon landscape elements to mature along their shared property lines to provide privacy or a permeability between their properties. The agreed upon landscape elements would be planted level with grade and blend in with the surrounding topography. This strategy would replace continuous fence planes with natural landscape elements that help people to maximize the area of their properties and save the money that would otherwise be used to build hundreds of feet of fence.

3.4 Program

The general program of the (individual) proposed homes will stay the same compared to the homes that will be built. However the arrangement of the proposed program will be different from the way the program is arranged on the homes that will be built. (see

fig.14) Parking will be provided as outdoor or covered and unconditioned and will be moved behind the homes. This is to save cost as the proposed homes utilizing hybridized building methods will have higher initial costs compared to the homes that would have been built. The overall square footage of the proposed homes will be slightly smaller than the homes that will be built due to the thicker walls of the proposed buildings.

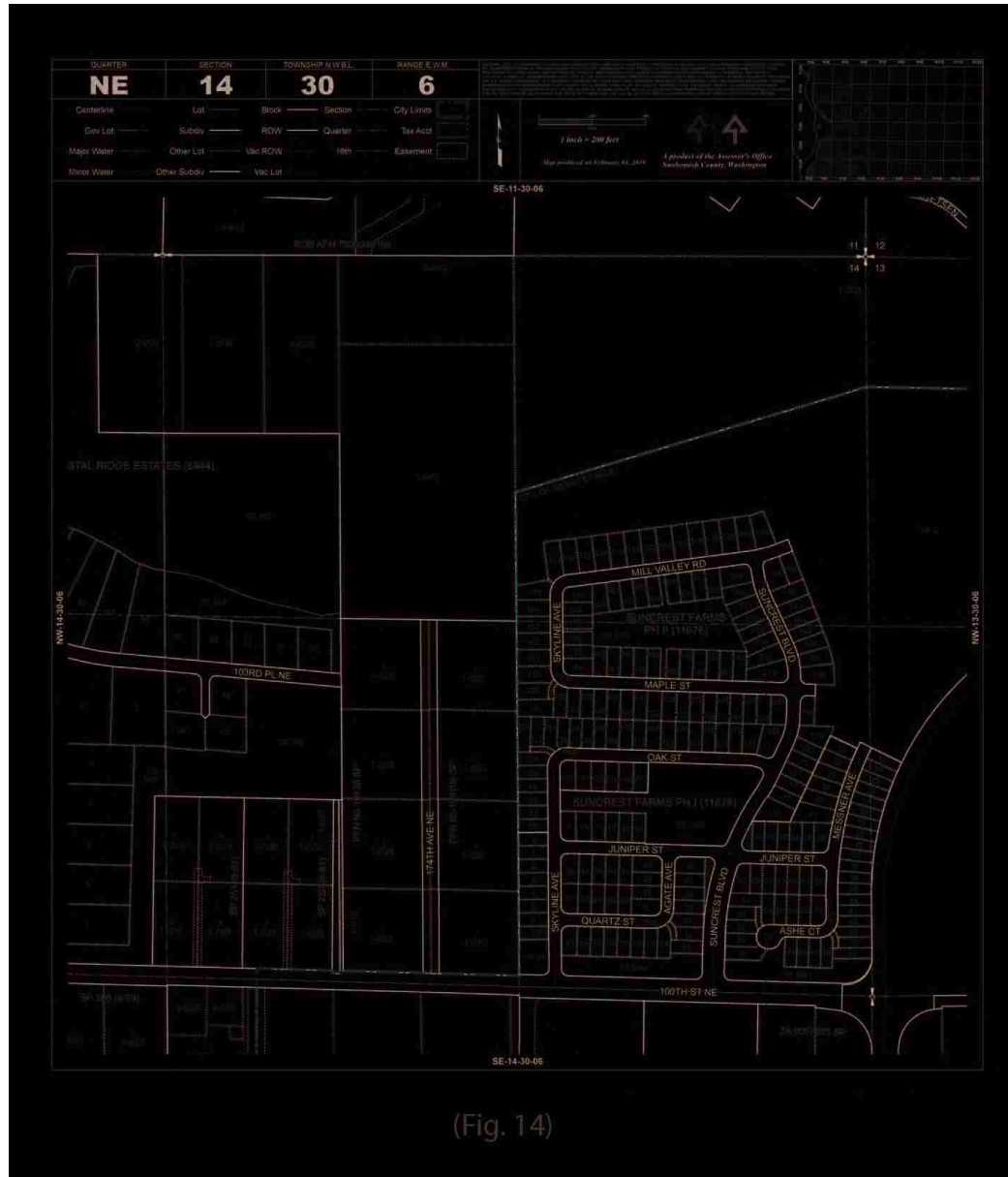

(Fig. 14)

3.5 Chapter 3 Citations

- Birkeland, Janis. *Design for Sustainability : A Sourcebook of Integrated, Eco-logical Solutions*. London ; Sterling, VA: Earthscan Publications, 2002. Print.
- Bray, Kari. “Granite Falls Housing Development Starts to Take Shape.” *HeraldNet.com*, HeraldNet.com, 5 Dec. 2016, www.heraldnet.com/news/granite-falls-housing-development-starts-to-take-shape/.
- Duany, Andres., Plater-Zyberk, Elizabeth, and Speck, Jeff. *Suburban Nation : The Rise of Sprawl and the Decline of the American Dream*. 1st ed. New York: North Point, 2000. Print.
- “Granite Falls, Washington.” *Wikipedia*, Wikimedia Foundation, 2 June 2019, en.wikipedia.org/wiki/Granite_Falls,_Washington.
- Hou, Jeffrey, Francis, Mark, and Brightbill, Nathan. *(Re)constructing Communities : Design Participation in the Face of Change : The 5th Pacific Rim Conference on Participatory Community Design*. Davis, CA: Center for Design Research, U of California, 2005. Print.
- Kirk, Ruth. , and Alexander, Carmela. *Exploring Washington’s Past: A Road Guide to History*. Rev. ed. Seattle: U of Washington, 1995. Print.
- Snohomish County. Planning and Development Services Planning and Technology Division. *Snohomish County UGA Land Capacity Analysis Technical Report*. June 10,2015.<https://wasnohomishcounty2.civicplus.com/DocumentCenter/View/31364/2015-Land-Capacity-Analysis?bidId=> Web.
- Woodhouse, Philip R., Jacobson, Daryl, and Petersen, Bill. *The Everett and Monte Cristo Railway*. Arlington, WA: Oso Pub., 2000. Print.

Fig. 9-<https://www.google.com/maps>

Fig. 10-<https://snohomishcountywa.gov/1402/Maps-GIS>

Fig. 11-<https://snohomishcountywa.gov/1402/Maps-GIS>

Fig. 12-<http://ci.granite-falls.wa.us/?lsvrdocument=2016-zoning-map>

Fig. 13-<https://www.google.com/maps>

Fig. 14-<https://snohomishcountywa.gov/1402/Maps-GIS>

CHAPTER 4: DESIGN RESPONSE

4.1 Introduction

In considering the application of a hybridized method of construction for this site in Granite Falls, the following chapter will address both site response and a building methods response. The site response will begin with analysis at the scale of the development, moving into details for each particular site. For the building methods response, specific materials and methods have been chosen. The historic materials are: straw bale, cord wood, and stone masonry and the contemporary materials and methods are: heavy timber, clt, sheet metal shear panels, solar energy capture, storm water capture, and radiant and wall mounted cassette heating. The attributes of these materials and methods are evaluated under the categories of energy, place, health, and constructability. Fig.15 shows how the hybridization of historic and contemporary building methods is symbiotic. The weaknesses of one building material or method can be offset by another. (see fig.15) The labor intensiveness of historic building methods can be neutralized by better productivity linked to contemporary building methods. The costliness of contemporary methods can be balanced by the frugality of historic methods. The specialized skill associated with contemporary building methods can be counter balanced by the inclusiveness of skill needed to execute historic methods. The highly processed manufacture of contemporary materials can be balanced out by the minimally processed attributes of historic building materials.

4.2 Site Response

The existing site layout has maximized the quantity of houses while minimizing the quantity of paved surfaces (sidewalks and streets). (see fig.16) This strategy has sacrificed the ability of many of the homes to fully utilize natural lighting. Homes that have lots that are elongated East to West or vice versa have their Southern exposure compromised as neighboring homes are only ten feet away on either side, blocking most of the natural light from mid-morning through early evening throughout most of the year. Curb cuts are

ATTRIBUTES OF BUILDING MATERIALS AND METHODS

	ENERGY Embodied and Operational	PLACE Identity and Locally Sourced	HEALTH Individual and Environmental	CONSTRUCTABILITY Assembly and Disassembly
ENVELOPE				
STRAW BALE	Low Embodied Energy Low Life-Cycle Costs	Locally Sourced	Non-Toxic	Easily Repurposed
CORD WOOD	Low Embodied Energy Low Life-Cycle Costs	Locally Sourced Expressive of Logging	Non-Toxic	Easily Repurposed
STRUCTURE				
STONE MASONRY		Locally Sourced Expressive of Mining	Non-Toxic	Easily Repurposed
HEAVY TIMBER		Locally Sourced	Fire Resistant	Expedient Easily Repurposed
CLT	Highly Processed		Fire Resistant	Expedient Easily Repurposed
METAL SHEAR PANEL	Highly Processed	Locally Sourced		Expedient Easily Repurposed
SYSTEMS				
SOLAR PV PANELS AND WATER HEATER				
WATER CATCHMENT/ STORAGE			Mitigates Storm Water Runoff	
RADIANT/ WALL MOUNTED HEATING WITH GROUND SOURCE HEAT PUMP AND HEAT RECOVERY VENTILATOR				
	GOOD			LESS GOOD

(Fig. 15)

What Is VS. What Ought to be
Site: Housing Development Layout

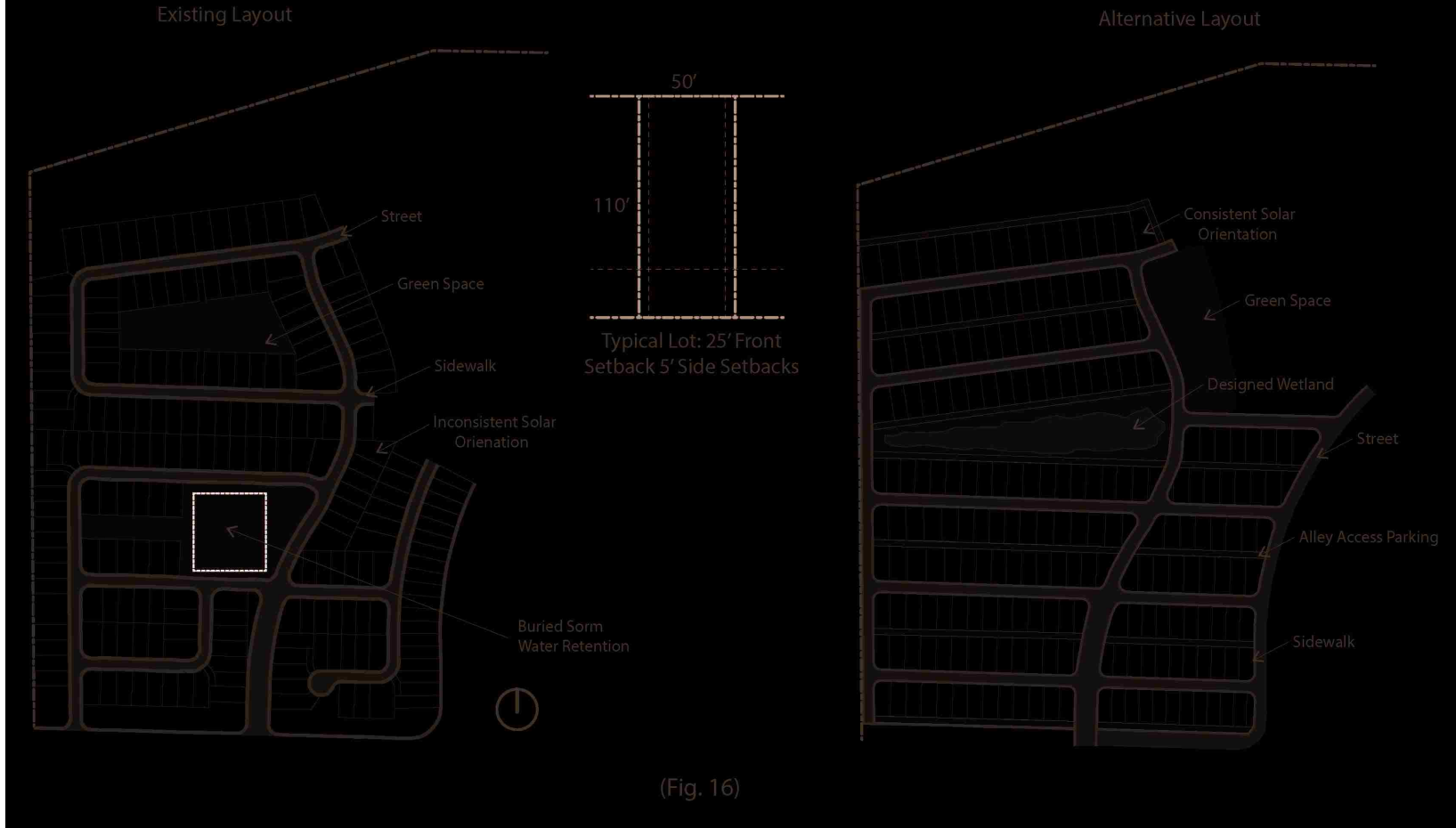

(Fig. 16)

required off of the street that then feed into each homes front driveways that have to be as long as the setbacks of the lot to reach each home. These curb cuts periodically inhibit the continuity of pedestrian traffic flow, and put children and the elderly at greater risk from vehicular injuries. Storm water retention tanks help mitigate the periodic strain on the capacity of the storm water system by containing large quantities of storm water before they have to be sent down stream. Utilizing plants that could consume a portion of the excessive storm water with a designed wetland would reduce the amount of water that is typically sent down stream.

The proposed site layout gives consistent solar orientation to all of the houses so that there is an equitable opportunity for all residents of the development to utilize natural lighting opportunities. (see fig.17) This consideration gives designers consistent circumstances under which they are required to design with for all of the houses in the development. Alley access parking serves many purposes. The distance between the backs of adjacent homes is increased, improving the quantity of natural light that could be utilized. Moving parking to the rear of each house makes front yards more practical and improves the curb appeal for each home. No curb cuts for driveways are needed off of the street pedestrian safety is improved. Garbage and recycling services can be picked up from the allies further improving the curb appeal of homes. Designed wetlands consume some of the excess storm water while retaining some of the excess water as well.

4.3 Structural Response

4.3.1 Foundations: Stone Masonry

A typical formed and poured concrete foundation is excessively durable. Most houses that face demolition rest on uncompromised foundations that face the same demolition as the houses that rest upon them. Because the footing must bear on undisturbed soil of adequate compressive strength much of each building site must be heavily excavated. Many of the pier pads that have posts that bear the weight of much of the interior of the house are often poured on compromised soils, leading to eventual settlement. Having a

What Is VS. What Ought to be
SITE: Solar Orientation

Existing Site Layout

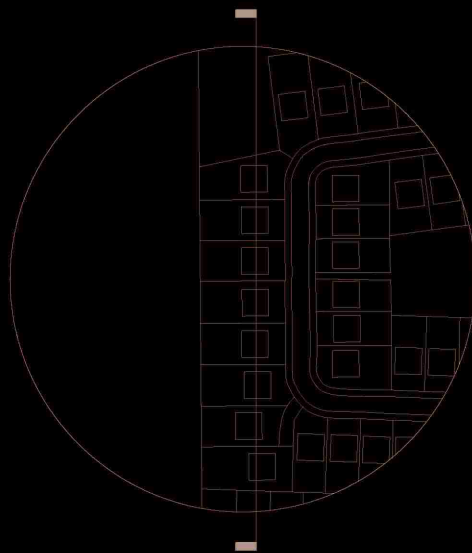

SUN ALTITUDE AT WINTER AND SUMMER SOLSTICE
SHADOWS: WINTER SOLSTICE

SUN PATH AT SUMMER AND WINTER SOLSTICE
DEGREES OF ALTITUDE

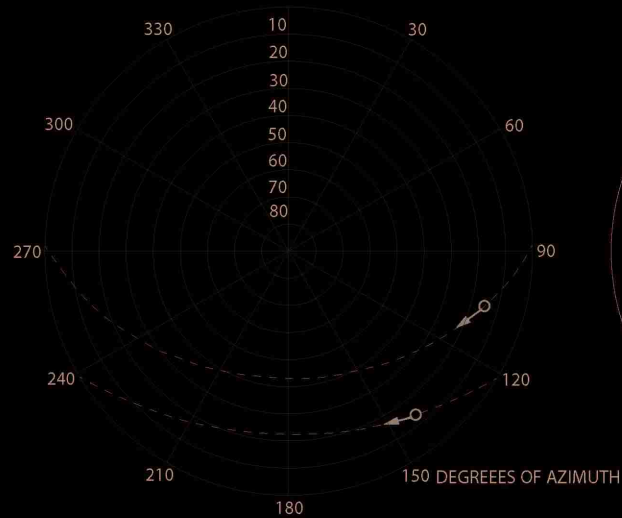

FEET $\frac{16}{32}$ 64



(Fig. 17)

Alternative Site Layout

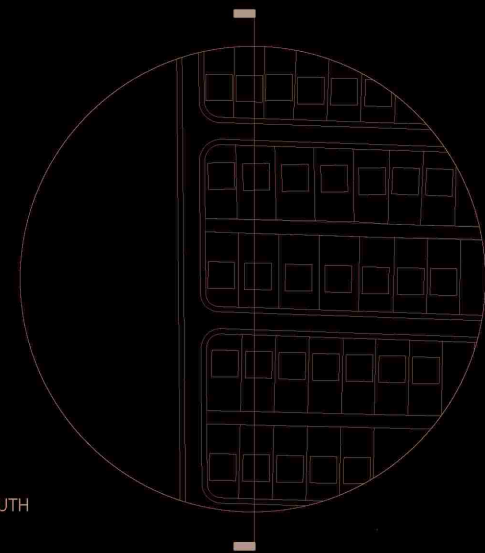

SUN ALTITUDE AT WINTER AND SUMMER SOLSTICE
SHADOWS: WINTER SOLSTICE

crawl space to house systems facilitates the need for flooring systems that serve as both structure and insulate against the cold.

Stone masonry foundations that are built higher above grade than conventional foundations address the danger of possible flooding in the area and make the homes more resistant to such natural hazards. (see fig.18) The concrete slab floor simplifies the flooring system on the first floor and opens the opportunity to have radiant heating coils embedded into the slab for a radiant heating system on the first floor. While the construction process of a stone masonry foundation is more complex and involved compared to a conventional foundation the stones themselves are more easily repurposed when the foundation faces demolition compared to a conventional foundation. Because the stones can be locally sourced there is less embodied energy in the foundation compared to a conventional foundation. The stone masonry is expressive of the mining industry that continues to thrive in the Granite Falls area. Stone masonry foundations help the architecture to better represent the place it resides and its accompanying identity. The grade beam that supports the masonry stem wall has a width much greater than a conventional foundation, this width makes the use of straw bales in the envelope system possible. Stone masonry foundation walls express a higher level of craft compared to conventional foundations

4.3.2 Building Frame: Heavy Timber

Conventional structural systems are composed of adequately sized members that are dependent on a great quantity of fasteners. Seismic straps protrude from foundations and attach to these members with another great quantity of fasteners. While a typical structural system can be constructed expediently the nature of the system condemns it to nearly certain demolition when the life of the home has reached its end. Because of the regular spacing of structural members in a typical structure most individual members are compromised to accommodate systems such as electrical, plumbing, and heating. Insulation is then expected to perform after having to weave around all these various systems.

Heavy timber structural systems can be assembled expediently. Because the fasteners used in this system are larger than con-

What Is VS. What Ought to be
Structure: Foundation

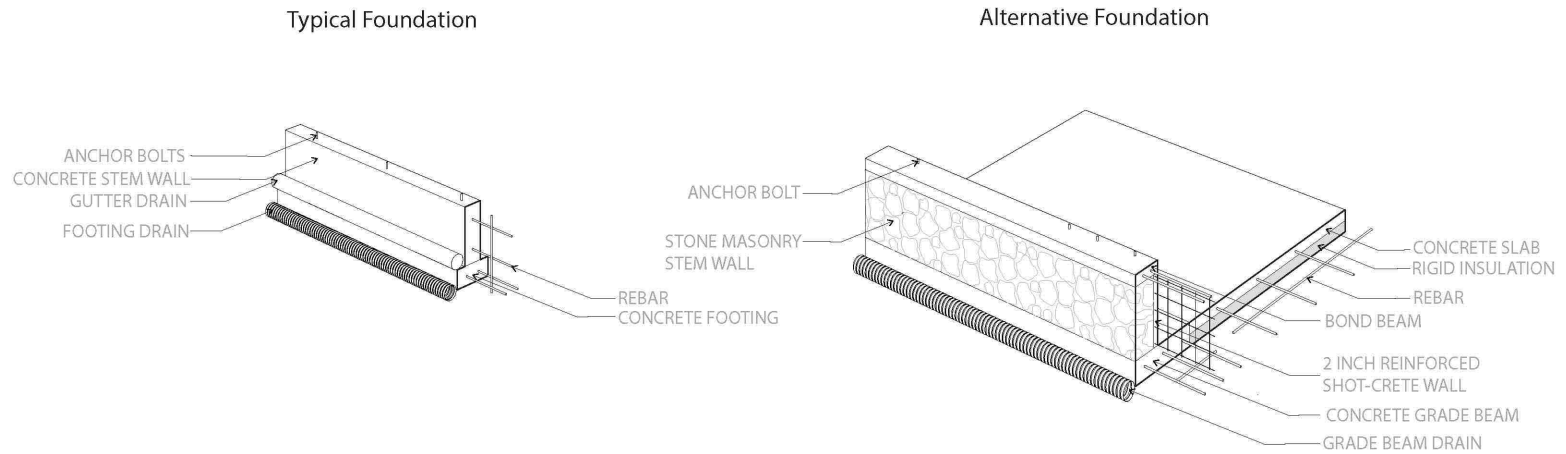

(Fig. 18)

ventional fasteners used and are typically threaded and or bolted together this makes the eventual disassembly much more plausible compared to a typical structural system. Heavy timber works well in conjunction with the other structural and envelope systems that are proposed. By separating the structure from the insulating portions of the envelope the proposed wall assemblies eliminate the need to notch straw bales to be integrated with the heavy timber. Heavy timber can be locally sourced. It is more resistant to fire than conventional stick framed structural systems. The constructability of a heavy timber structural system helps to offset the time intensive nature of some of the other building materials/methods that are proposed in conjunction with heavy timber.

4.3.3 Flooring System: CLT

What makes typical structural floor systems so problematic is the amount and characteristics of the fasteners used in the assembly. Sub-floor adhesives dry very hard and often remain adhered to multiple layers of a typical flooring system when demolished, nearly eliminating any opportunity of repurposing the materials of the system when demolished. In addition to the sub-floor adhesive ring shank nails are used to attach the OSB tongue and groove sheeting used to create the deck surface on top of the floor joists. Most developers come back to the home when the framing is complete and screw the floor down for additional strength and to prevent eventual squeaks in the floor. The screws used are often square drive that often have their heads stripped out while they are being installed, further complicating any eventual demolition or adaptation that has to take place to the flooring system. The screws used to fasten the sheet rock (gypsum wall board) on the underside of floor joists are then covered with sheet rock mud, further complicating any eventual disassembly.

CLT (Cross Laminated Timber) can be assembled expediently. (see fig. 19) The panels alone can span much greater distance than typical floor decking (not counting the joists spanning capabilities). This spanning ability allows structural members to be spaced at greater distances minimizing the overall quantity of structural members and subsequent fasteners. The panels are stitched together

What Is VS. What Ought to be
Structure: Frame

Typical Structural Frame

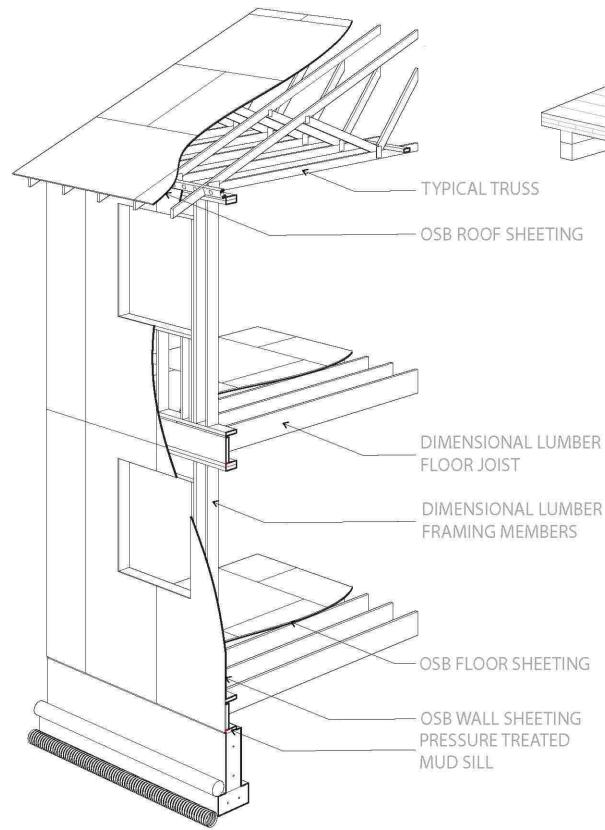

Alternative Structural Frame

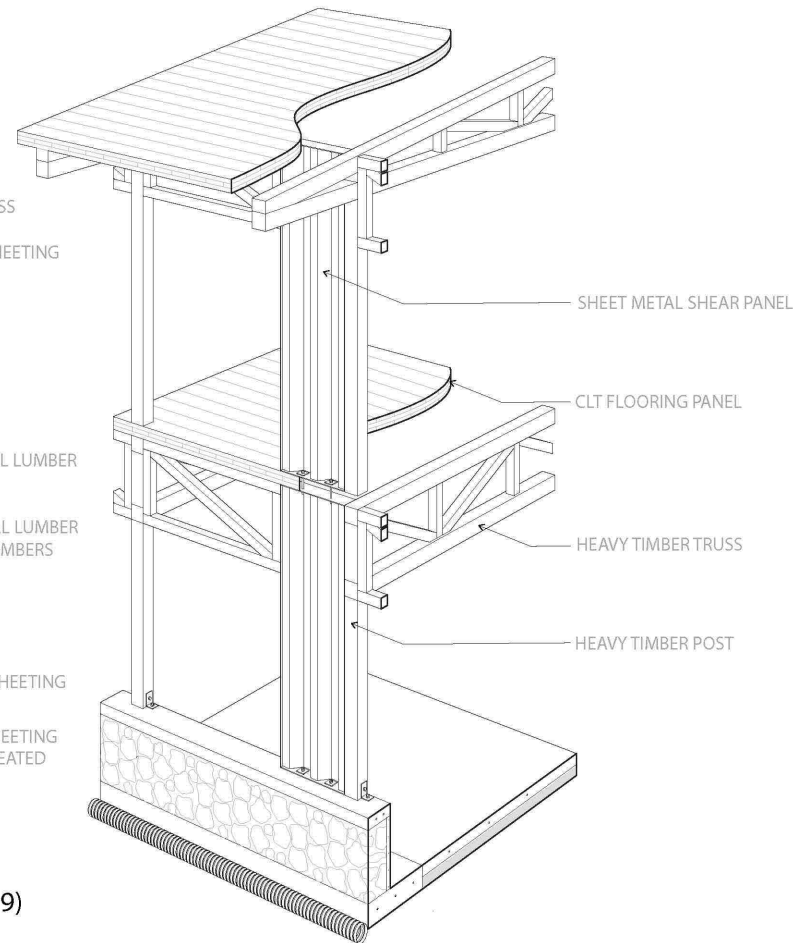

(Fig. 19)

with hexagonally headed high strength screws. These screws can be removed easier than they can be installed promoting the possibility of eventual reuse of the CLT panels. Because of the thickness of the panels and the ease at which fasteners can attach to them the layering of structural systems onto the CLT panels is less problematic.

4.3.4 Lateral Support: Metal Shear Panel

Typical wall assemblies achieve their shear strength from OSB sheets that are nails with great regularity along the edges of the sheets into the wall studs and plates that are dimensional lumber. OSB is known to off-gas harmful fumes that are detrimental to construction workers and the eventual inhabitants of the homes. OSB cannot be repurposed for the same purpose it was first used for (if disassembled) because nails would have to be attached in the same locations as when first installed otherwise the structural integrity of the sheet will be compromised with additional penetrations.

Metal shear panels use fewer and larger fasteners that can be removed as easily as they can be installed. Because of their greater shear strength compared to typical wall systems fewer metal shear panels can be used to generate the same shear strength compared to a typical wall assembly. There are many small scale metal fabrication businesses in the Granite Falls area that could be contracted to produce the needed metal shear panels, supporting further use of locally sourced materials to construct the proposed homes. Because metal shear panels would be integrated with the heavy timber at the outside layer of the building it the panels could be painted and serve as cladding in addition to its structural characteristics.

Showing conventional and alternative structural arrangements at full scale shows additional drawbacks to the conventional system and the benefits of the alternative. Conventional framing arrangements are dependent on additional beam lines, bearing walls, and shear walls as the spanning capabilities of dimensional lumber are limited. (see fig.20) This structural arrangement limits the adaptive capabilities of the resulting floor plans. Using heavy timber trusses for floor and roof assemblies allows for greater adapt-

What Is VS. What Ought to be
Structure: Frame

Dimensional Lumber and OSB Sheeting

- Bearing Walls and Beams
- Interrupts full span
- Inflexible Floor Plan
- Maladaptive Exterior
- Rough Openings
- Tedious Assembly
- Problematic Reuse

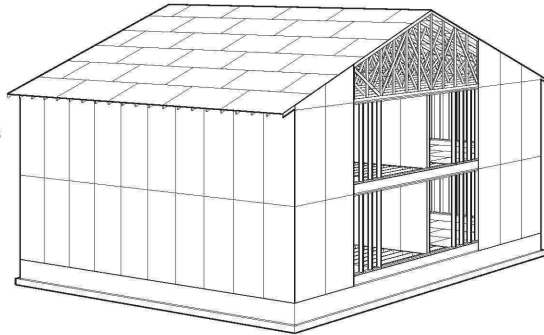

Heavy Timber Posts and Trusses

- Full Span Trusses
- Adaptive Floor Plans
- Greater Spacing
- Facilitates Adaptive
- Exterior Rough Openings
- Expedient Assembly
- Possible Reuse of
- Materials

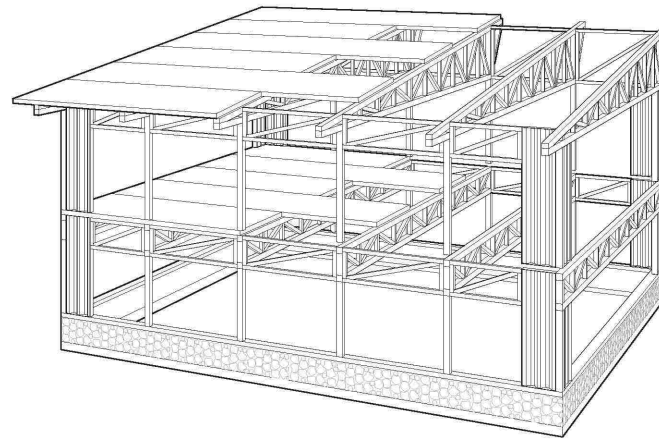

(Fig. 20)

ability of floor plans as any partitions would not be bearing walls and could be relocated much easier than the walls of conventional structural framing plans. Conventional framing arrangements require members to be placed at every sheeting seam and have to stack on top of every previous structural member. Making the integration of rough openings into the wall assemblies more difficult compared to the alternative structural arrangement which does not depend on OSB sheeting or structural members every 16 inches.

4.4 Envelope Response

4.4.1 Insulation: Straw Bale

The fiberglass insulation used to insulate the walls, floors, and attic spaces in typical suburban homes is very energy intensive in its manufacture. It is also often transported from great distances to reach the home it is to be installed in. Both of these factors contribute to fiberglass insulation having high embodied energy, despite it being very economical. Each of the studs, joists, and trusses that the insulation is installed between has thermal breaks wherever a structural member interrupts the continuous blanket of insulation that the insulation is trying to create. (see fig. 21) All the layered systems that are woven through wall and floor systems further obstruct the performative value of fiberglass insulation. Particulates can be a skin irritant for the workers who are exposed to the particulates that remain air-born (from the insulation) until it is concealed behind subsequent assemblies.

Straw bale out performs the insulation performance of conventional fiberglass insulation when straw bale courses are continuous and the bales are arranged with the thickest dimension of the bales to give the greatest possible depth to the walls. Separating the structure from the straw bale courses improves ease of installation and thermal performance. The improved insulation performance reduces home owner's monthly heating and cooling bills reducing the life cycle or operational costs of the system. Straw bales are an agricultural byproduct and can be sourced from Eastern Washington giving the material low embodied energy. Straw bales have no additives within them making them safe to work with and repurpose when their initial purpose has come to an end. Typical straw bale

What Is VS. What Ought to be
Envelope: Insulation

Typical Fiber Glass Insulation

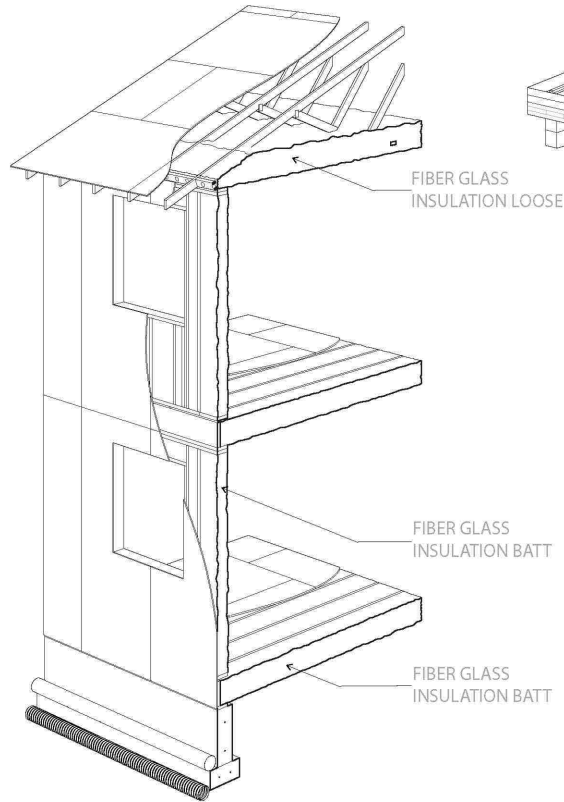

Alternative Straw Bale and Rigid Insulation

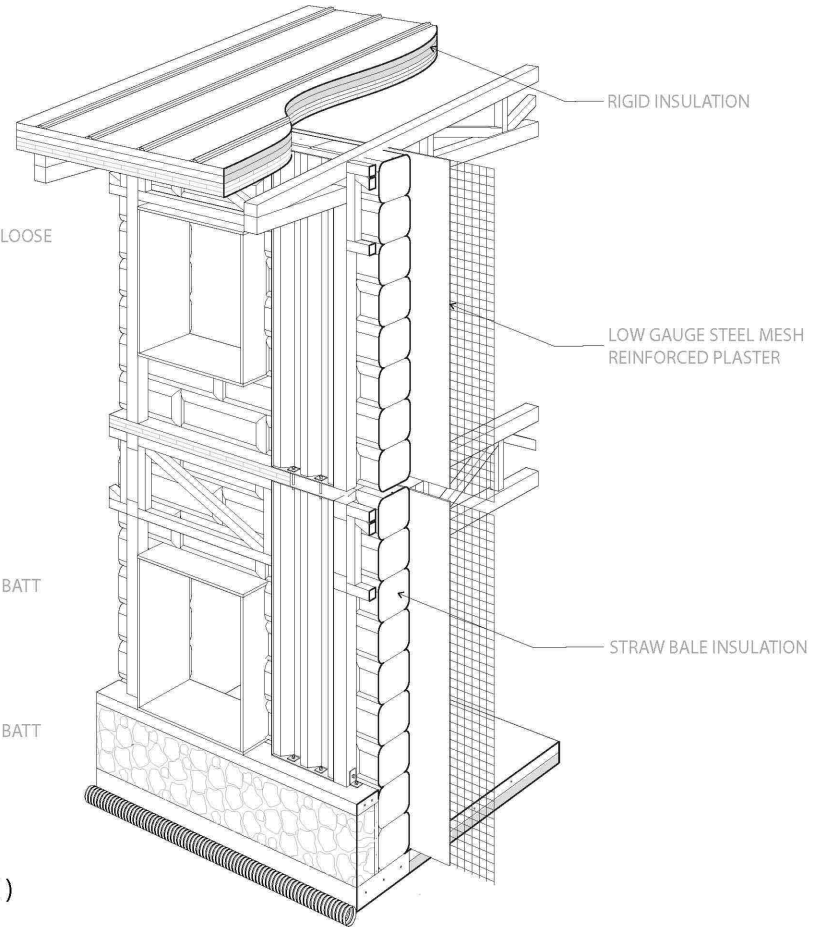

(Fig. 21)

wall assemblies rely on an outer layer of concrete applied over a wire mesh that has been attached to the structure. By using the straw bales for insulation and a surface to apply interior finishes eliminates the need for a thin shell concrete layer that is problematic to recycle.

4.4.2 Cladding: Cord Wood

While conventional hard plank siding can be commended for using abundant materials such as sand and wood pulp in their manufacture they also use epoxy add mixtures and the siding uses great quantities of energy to heat the siding to high temperatures during their manufacture. For the life of the house the siding is dependent on paint for protection. Periodic application of this paint is needed periodically and can cost a good deal when having a contractor do the work. Ring shank nails are used to fasten each course of siding, these nails are difficult to remove and the heads of the nails often break off during removal. Further complicating any possible reuse is the brittle quality of the siding that would also complicate and possible disassembly. The fasteners puncture the moisture membrane that has been applied prior to the siding, these punctures invite moisture to wick into deeper layers of the wall assembly.

Cord wood alternatives to plank siding improve upon many of the characteristics of a conventional system. The typical application of cord wood for a wall assembly is deficient in many regards. Excessive wall width is needed to reach equivalent performance of a typical wall assembly. The cord wood rows are expressed on the exterior and the interior which some people would characterize as overly busy or too rustic looking. The greatest benefit of a cord wood wall assembly is the surface of the wall never needing paint. Cord wood is abundantly available near Granite Falls and is expressive of the logging industry that is stationed near the city. Adapting the application of cord wood to be integrated into the wall assembly composed of heavy timber, straw bale, and metal shear panels makes most sense to be used as an infill between structural members, windows, and metal shear panels. (see fig.22)

What Is VS. What Ought to be
Envelope: Skin

Typical Envelope Skin

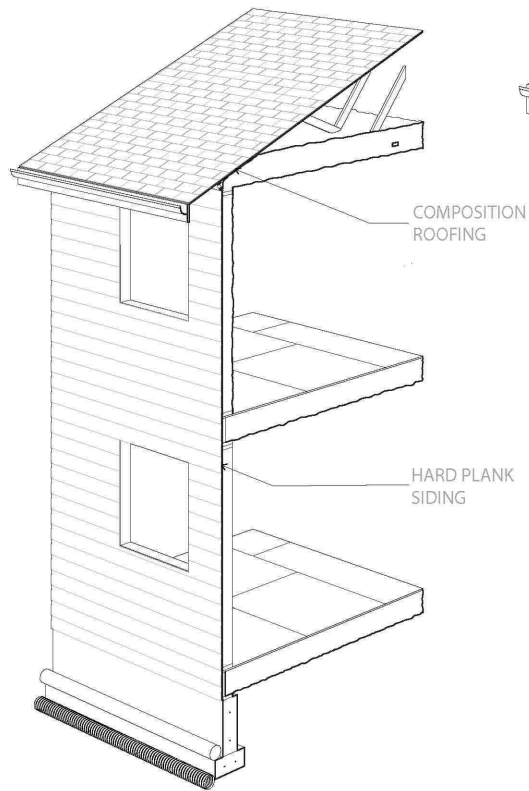

Alternative Envelope Skin

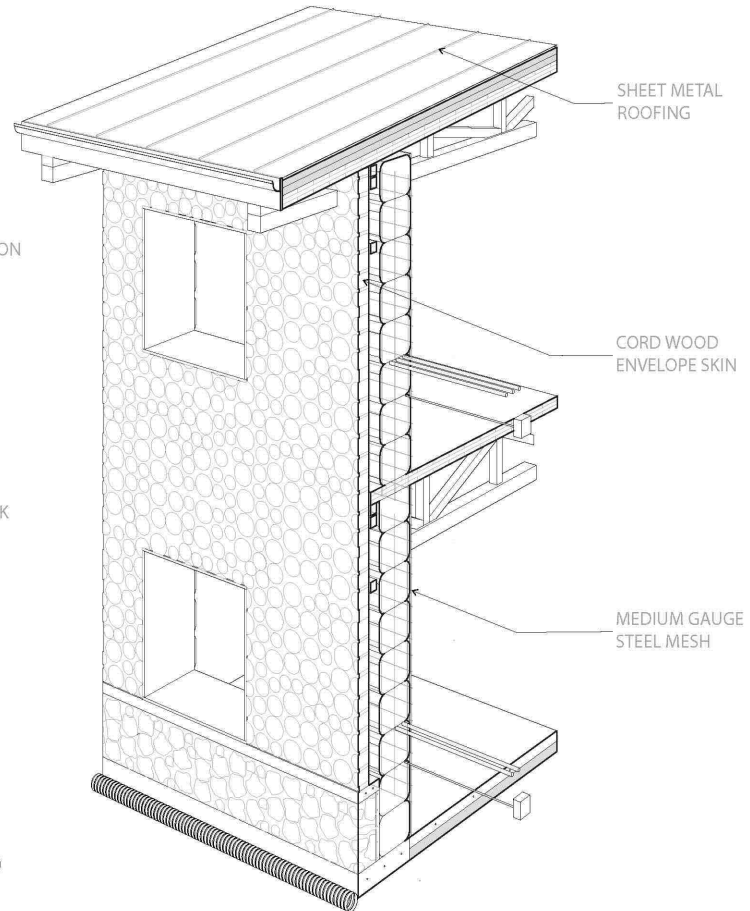

(Fig. 22)

4.5 Systems Response

Most historic systems are inefficient or release excess amounts of pollution such as oil heaters. This is why all the systems chosen to be implemented on the proposed homes are contemporary system responses. The storm water capture addresses the ecologic sensitivity on the site and the heating and solar energy capture address lowering home owner's monthly utility bills and reducing the burden on the infrastructure from the added demand of several hundred new homes.

4.5.1 Water Catchment and Storage

Capturing storm water to supply toilets addresses the ecologic sensitivity of the site. This captured water would otherwise feed into local rivers. Holding tanks would store and then use this water instead of fueling any possible flooding downstream. A ten thousand gallon tank is adequate for providing most of the water needed to supply toilets for a family of four throughout the entire year. The yearly needs that toilets have for water in a situation with four users requires about thirty thousand gallons of water. A generically sized roof surface has the potential to harvest over forty thousand gallons of water. The production totals of water captured from storm water for toilet usage is greater than the needs making the system more plausible. If potential home owners are having budget constraints that are keeping them from buying a home of the type suggested the storm water capture system could be built later on by the homeowners to reduce initial cost of the home. (see fig.23)

4.5.2 Heating

Ground sourced heat pumps utilize the ambient temperature of the ground soil below the freezing level in the ground. Radiant heating eliminates the need for the space hogging duct work of typical forced air heaters that compromise the structural integrity of typical homes. Radiant heating helps to keep the humidity of the conditioned air at healthy levels while forced air systems take some of the moisture out of the air. Wall mounted cassette heaters conserve energy as the entire house is not expected to remain the same

What Ought To Be
System: Storm Water

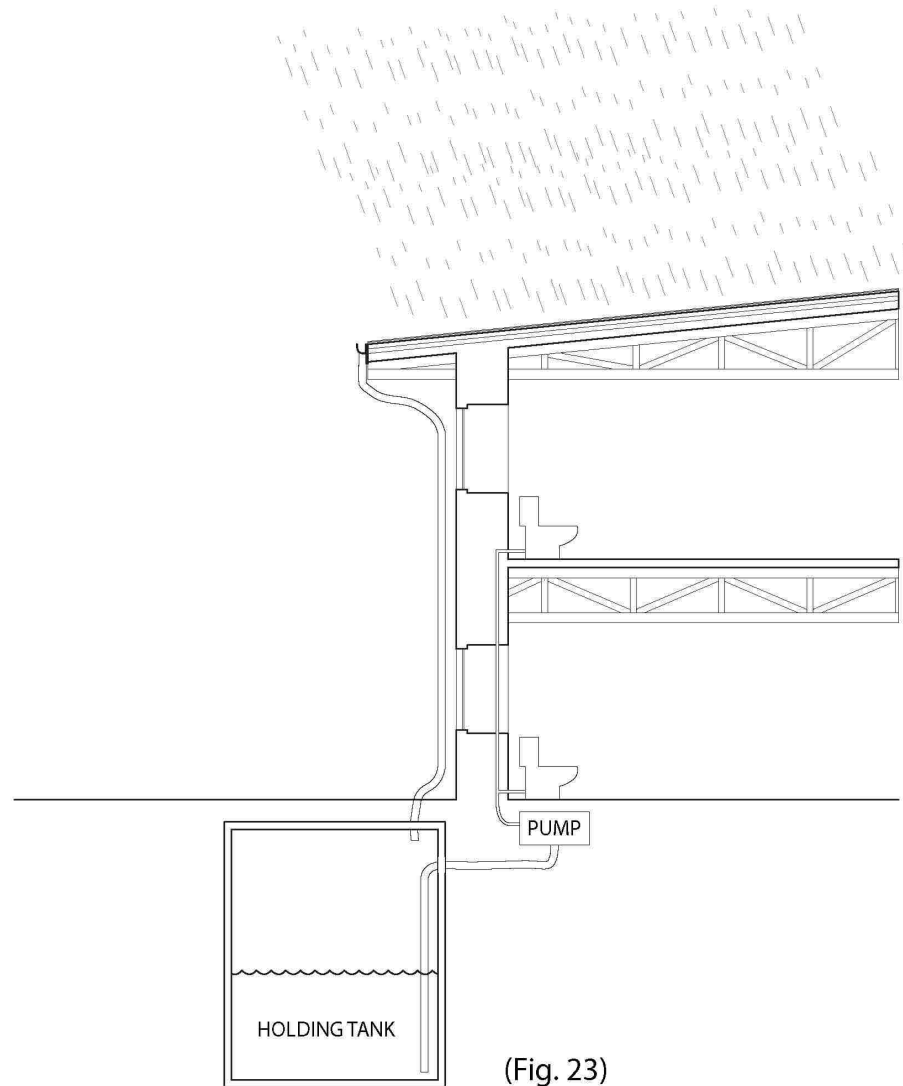

temperature as in typical heating systems with few thermostats. Heat recovery ventilators are very economical and help to preheat incoming air with exhaust air. (see fig. 24)

4.5.3 Solar Energy Capture

Capturing and converting solar energy on site reduces the increased demand on the infrastructure due to the hundreds of new homes built in the development. Monthly utility bills would be lower which would help to offset the increased initial cost of the proposed systems over time. Assuming a home footprint of forty foot by forty foot with liberal roof overhangs, a 25KW photovoltaic array can fit on the roof, even assuming some of the space will be used for evacuated tube solar water heaters. (see fig. 25) According to newsenergysage.com a 25KW photovoltaic array in the Seattle area is capable of providing seventy five percent of the overall electricity needs. According to the same web site the main constraint of using this system (of that size) is that the cost would be around fifty thousand dollars including the reduction in price from tax credits.

Evacuated tube solar water heaters are very efficient at converting the sun's energy into heating water. The heated water would circulate down into a pre-heat tank that would have the hot water supply pipes running through but not connected. This setup helps solar energy to increase the temperature of any water that will eventually be heated by the on-demand water heater, reducing the effort this system component has to work to heat the water to the desired temperature of anyone or appliance that requires hot water.

4.6 Conclusions

The context of a site is integral in determining building materials and their corresponding methods of application. Site conditions can architecturally sculpt these materials appropriately. The continued history of a site can be expressed architecturally and help residents to feel a heightened sense of place and pride in their community. Building strategies can elevate the quality of hybridized building methods to strengthen the overall performance of the proposed homes.

What Ought To Be System: Heating

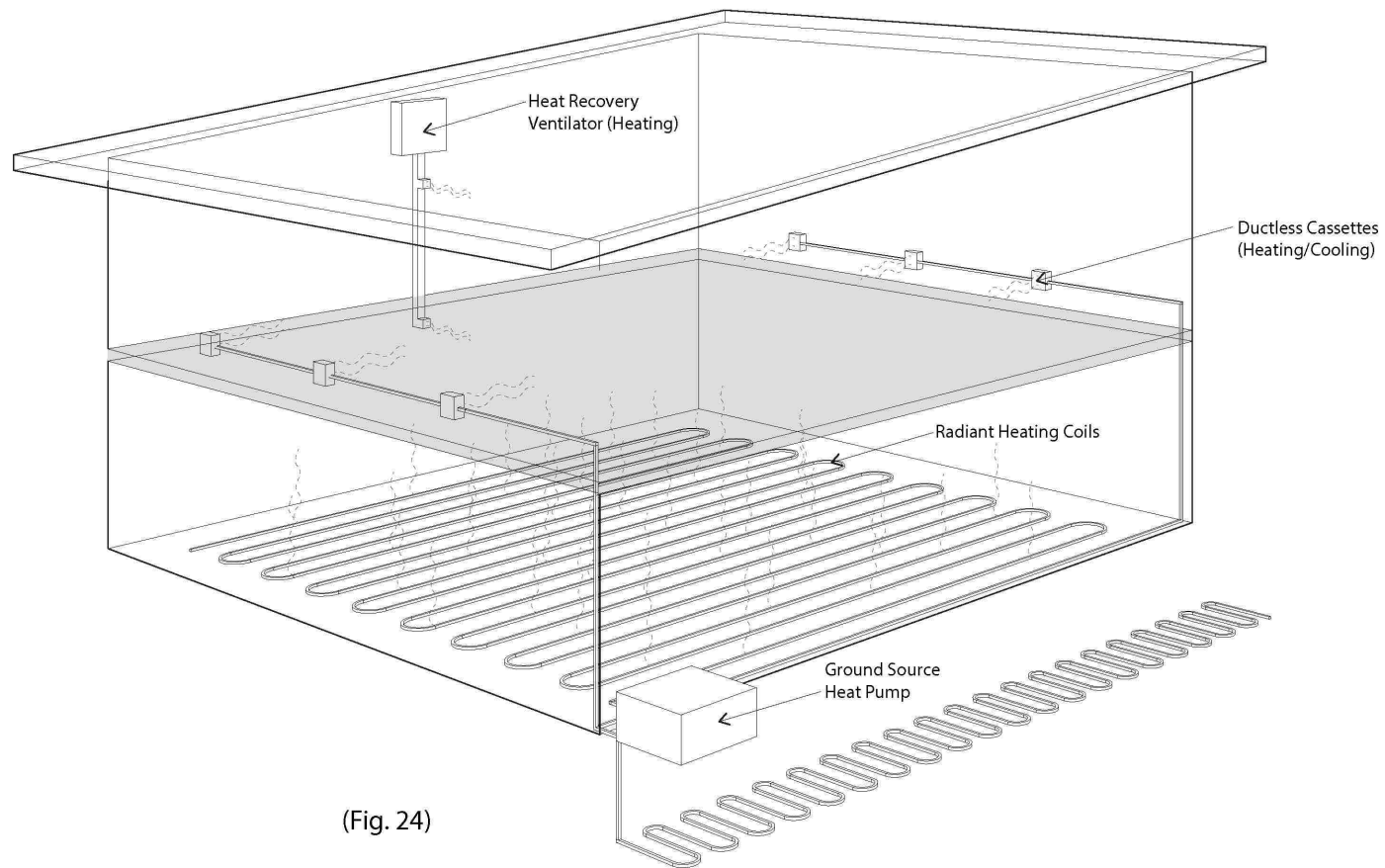

(Fig. 24)

What Ought To Be System: Solar Energy Capture

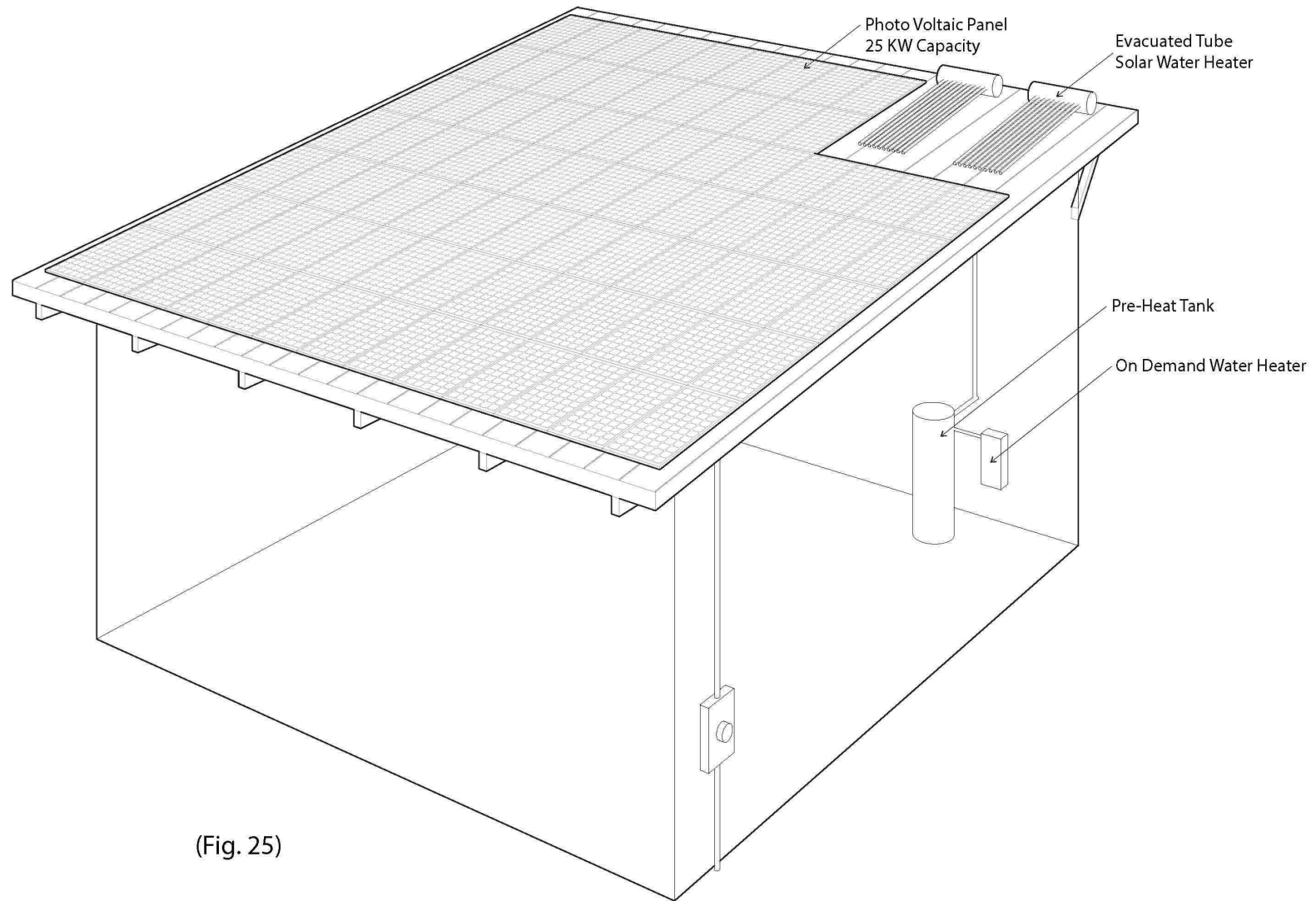

(Fig. 25)

The standardization of typical building systems on suburban homes neglects all the possible alternatives offered by traditional and conventional building methods and materials. A hundred years from now all of us will be dead and gone. We have an opportunity in our life-times as home builders to displace disposable, placeless, toxic, and ecologically and environmentally short sighted homes with homes that minimize embodied energy, life-cycle costs, and toxins while embellishing the identity of the place in which they are built.

Testing the ideas of this thesis at different locations that are equally rich or meek in their availability to provide locally sourced building materials would result in different design solutions than what this thesis has arrived at. Another designer making the same general propositions I have made may arrive at the use of different building methods and materials than I have in the same place I have chosen. A home built in a different location near downtown Seattle may have brick walls that have been locally sourced from stock-yards wealthy in brick that has been demolished from buildings all over King County.

Having built residential homes as a framing carpenter for twelve years imagining an alternative way of constructing homes has helped me to reconcile the guilt I feel from building so much garbage disposable architecture for all those years. Continuing to investigate the ideas of this thesis into the future I would like to do cost estimating and performative analysis of the building assemblies and systems that I have proposed.

4.7 Citations

Fig. 15-25-Generated by Dylan Cotton